

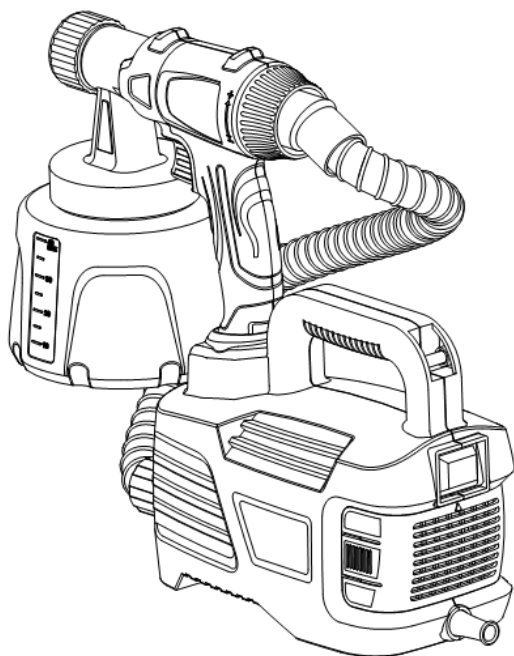

USER MANUAL

ELECTRIC SPRAY GUN — ASPRAY-013



Please read this instruction manual before using your new power tools

Contents

Page

Safety instructions for electric tools	2
Safety instructions for ASPRAY-013	3
Technical data ASPRAY-013.....	6
Explanation of the system.....	6
Functional description.....	6
Materials which can be used.....	7
Materials which cannot be used.....	7
Explanatory diagram ASPRAY-013.....	7
Preparation of the coating material.....	8
Measuring the viscosity with the viscosity measuring cup.....	8
Viscosity table.....	9
Starting up	9
Adjusting the spray gun.....	11
Choice of spraying effects.....	11
Adjusting the required spray effect.....	11
Adjusting the amount of material.....	11
Adjusting the amount of air and pressure.....	11
Spraying technique.....	12
Breaks in work	13
Closing down and cleaning	13
Troubleshooting.....	14

Safety instructions

For electric tools

Caution! Observe the following basic safety precautions when using electric tools in order to protect yourself against electric shock, danger of injury and fire.

Read and observe these rules before using the unit.

Keep the safety instructions in a safe place.

1. Consider environmental influences

Do not expose electric tools to rain. Do not use electric tools in humid or wet environment. Provide good lighting. Do not use electric tools near flammable liquids or gases.

2. Protect yourself against electric shock

Avoid contact with earthed objects such as pipes, radiators, stoves, refrigerators.

3. Keep your tools in a safe place

Unused tools should be kept in a dry, locked room out of the reach of children.

4. Do not misuse the cable

Do not carry the tools by the cable and do not use it to remove the plug from the socket. Protect the cable against heat, oil and sharp edges.

5. Maintain your tools with care

Keep your tools clean to ensure good and safe operation. Follow the maintenance instructions. Check plug and cable regularly. If defective, have them replaced by a service station or by an authorized dealer. Check the extension cable regularly and replace it, if defective. Make sure the extension cable is equipped with the prescribed earthing contact. Keep the handles dry and free from oil and grease.

6. Remove the mains plug

When the unit is out of use, before maintenance work and when mounting accessories.

7. Avoid unintentional start

Do not carry tools which are connected to the mains with your finger on the switch. Make sure that the switch is off when connecting the unit to the mains.

8. Outdoor extension cable

When working outdoors only use approved and respectively marked extension cables.

Safety instructions for ASPRAY-013

- Please read the operating instructions thoroughly and observe the safety instructions
- Only coating materials such as paints, enamels, varnishes, etc, with a flash point of 21 °C (32 ° in the United Kingdom) and above may be sprayed, without additional warming. In Germany these are coating materials in the danger classes A II and AIII, see paint tin.
- The device may not be based in work places which are covered by the explosion protection regulations.
- When spraying, ensure that there are no sources of ignition, e.g. open fire, cigarettes, cigars, and pipes, sparks, glowing wires, hot surfaces, etc, in the area.
- **Recommendation: wear breathing protection when spraying.**
- **Caution, danger of injury!**
Never point the spray gun at yourself or other persons or animals.

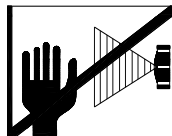

- When working with the device ASPRAY-013 inside and outside care must be taken that no solvent vapors are sucked into the device.
- When outdoors observe wind direction. When working indoors ensure that there is sufficient ventilation.
- Do not spray at the device.
- The device only splash-proof when the air hose is correctly connected.
- Do not let children play with the device. Keep out of reach of children.

- Care must be taken that the mains cable is not damaged. If damage is observed take immediately to an authorized customer service centre to be changed.
- Remove mains plug from socket when not in use.
- Repairs to electrical parts should only be carried out at an **authorized customer service center**.
- Do not use spray guns to spray flammable liquids.
- Do not clean spray guns with flammable solvents.
- Take precautionary measures against potential hazards from spray liquid and follow any instructions given on containers or laid down by the manufacturer of liquid.
- Do not spray any liquids of unknown hazard potential.
- Keep work area clean and well lit.
- Do not operate power tools in explosive atmosphere, such as in the presence of flammable liquids, gases or dust.
- Keep children and bystanders away while operating a power tool.
- Power tool plugs must match the outlet. Never modify the plug in any way. Do not use any adapter plugs with earthed (grounded) power tools.
- Avoid body contact with earthed or grounded surfaces such as pipes, radiators, ranges and refrigerators.
- Do not expose power tools to rain or wet conditions.
- Do not abuse the cord. Never use the cord for carrying, pulling or unpulling the power tool. Keep cord away from heat, oil, sharp edges or moving parts.
- When operating a power tool outdoors, use an extension cord suitable for outdoor use.
- Stay alert, watch what you are doing and use common sense when operating a power tool. Do not use a power tool while you are tired or under the influence of drugs, alcohol or medication.
- Use safety equipment. Always wear eye protection.
- Avoid accidental starting. Ensure the switch is in the off position before plugging in.
- Remove any adjusting key or wrench before turning the power tool on.
- Do not overreach. Keep proper footing and balance at all times.

- Dress properly. Do not wear loose clothing or jewellery. Keep your hair, clothing and gloves away from moving parts.
- If devices are provided for the connection of dust extraction and collection facilities, ensure these are connected and properly used.
- Do not force the power tool. Use the correct power tool for your application.
- Do not use the power tool if the switch does not turn in on and off.
- Disconnect the plug from the power source before making any adjustment, changing accessories, or storing power tools.
- Store idle power tools out of the reach of children and do not allow persons unfamiliar with the power tool or these instructions to operate the power tool.
- Maintain power tools. Check for misalignment or binding of moving parts, breakage of parts and any other condition that may affect the power tools operation. If damaged, have the power tool repaired before use.
- Use the power tool, accessories and tool bits etc, in accordance with these instructions and in the manner intended for the particular type of power tool, taking into account the working conditions and the work to be performed
- Have your power tool serviced by a qualified repair person using only identical replacement parts.
- **Forbidden to spray to the hatch of the the motor and etc.**
- **When spraying normally, the motor should not be under the head of the gun and the container**

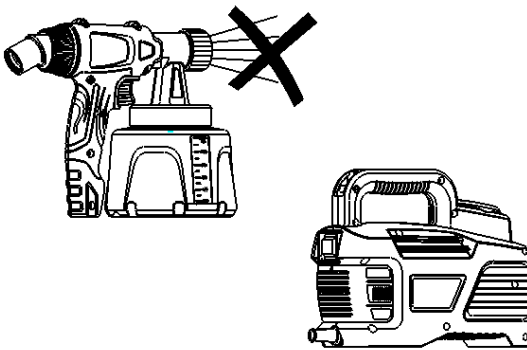

Technical data ASPRAY-013

Max. viscosity:	60DIN-s
Voltage:	220-240VAC 50Hz
Power consumption;	600W
Max. back air pressure:	0.1-0.3bar
Double insulation:	
Mains cable:	2m
Sound pressure level:	80 dB(A)
Oscillation level:	<0.25m/s²
Air hose length:	1.8m
Container capacity:	900ml/1200ml
Nozzle size;	Φ2.5mm
Weight:	2.5kg

Explanation of the system

The device works according to low pressure spraying technique. A high volume of air surround the spray jet being ejected under low pressure. The air cap provides a very fine atomization with the lowest of spray mist .The coating material is applied to the object quickly and exactly.

Moreover, the air flow shortens the drying time for the coating material. This gives perfect spraying result with a respective saving of coating material and is therefore good for the environment.

Function description

The motor blower produces a flow of air which flows through the air hose to the spray gun. The air flow atomizes the coating material at the nozzle and also pressurizes the container. This pressure pushes the coating material up the ascending pipe to the nozzle. The air and pressure setting can be adjusted progressively.

Materials which can be used

Solvent containing and water-dilutable enamel paints, vanishes, primers, two-component paints, clear enamels, motor-vehicle enamels, mordants and wood preservatives.

Materials which cannot be used

Wall paints (emulsions) etc., lyes and acid containing coating materials.

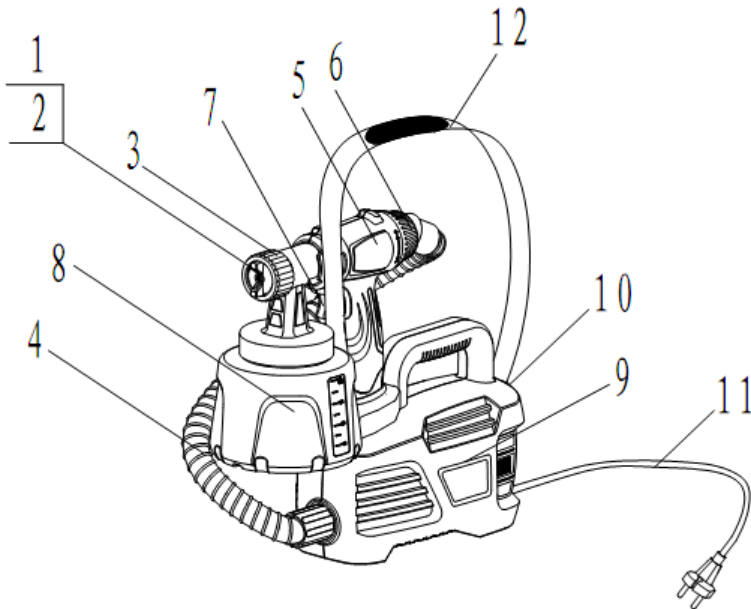

Exploratory diagram ASPRAY-013

- | | |
|-----------------------------|------------------|
| 1 Air cap | 7 Trigger |
| 2 nozzle | 8 Container |
| 3 Union nut | 9 Motor blower |
| 4 Air hose | 10 ON/OFF switch |
| 5 Spray gun | 11 Mains cable |
| 6 Material adjustment screw | 12 Strap |

Preparation of the coating material

Information regarding a sprayable dilution is normally not to be found on the material tin.

Therefore, use the viscosity table viscosity = thickness of the coating material page 9

Measuring the viscosity

using the viscosity

measuring cup

1. Thoroughly stir the coating material before starting measurement.
2. Immerse the viscosity measuring cup (contents 100cm^3) completely in the coating material below rim level and allow to fill.
3. Lift the viscosity measuring cup and measure the time in seconds until the flow of coating material stops.

This run-out time is called DIN seconds (DIN-s).

Viscosity table see page 9

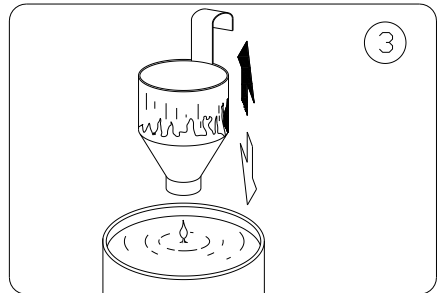

Viscosity table	
Coating material	Viscosity DIN-s
Solvent containing gloss paints -----	15-50
Primers -----	25-50
Mordants-----	undiluted
2 component paints-----	20-50
Clear varnishes-----	15-40
Water-dilutable gloss paints-----	20-40
Motor-vehicle enamels -----	20-40
Wood preservatives -----	undiluted

Place air hose end with pin in guide.

Secure by turning.

Spray gun end (fig.5)

Place the air hose firmly into the connection on the spray gun.

Starting up

1. Attach air hose .

Device end (fig.4)

Any position can be chosen for connection.

2. Unscrew the container from the spray gun .

3. Adjust the ascending pipe accordingly.

It should be possible to spray the contents of the container leaving hardly any material left in the container

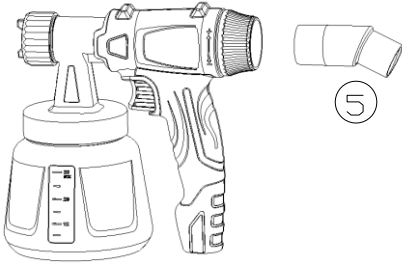

Spraying with horizontal objects (fig.7)

Turn ascending pipe A forwards.

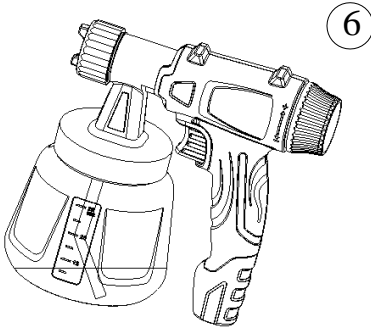

Spraying overhead objects (fig.6)

Turn ascending pipe A to point backwards.

4. Fill container with coating material. **Screw firmly onto spray gun.**
5. Place the spray gun in the spray gun holder.
6. Only place the device on an even and clean surfaces. Device could suck to dust ,etc.
7. Before connecting to the mains ensure that the mains voltage corresponds with the details on the rating plate.
8. Remove the spray gun from the spray gun holder and point at object to be sprayed. Turn on using.

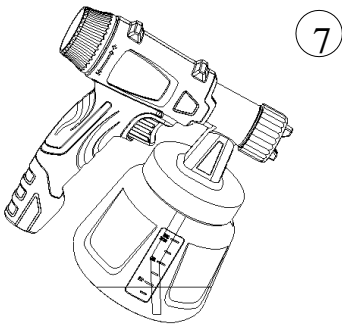

9. ON/OFF switch on the device.
10. Adjust the spraying pattern and amount of material; set the amount of air and pressure, see fig.8,9,10 and the description page 11.
11. Open trigger on the spray gun.

Note :

When the device is switch on the air will flow continually from the air cap

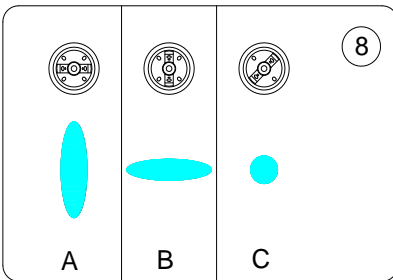

Adjusting the spray gun

Choice of spraying effects

A =vertical flat jet

for horizontal surfaces

B =horizontal jet

for vertical surfaces.

C =round jet

for corners and edges and other badly accessible places

Adjusting the required spray effect

With the union nut (3) loosed, turn air cap (1) to the required spray pattern.

Caution:

Never open trigger when making adjustments on the air cap.

Adjusting the amount of material

Adjust the amount of material by turning the adjustment screw.

+turn to the right –more material

-turn to the left –less material

Spraying technique

The spraying result depends considerably on how smooth and clean the surface is before spraying begins. For this reason the surface should be carefully prepared and kept free of dust.

Surfaces not to be sprayed should be covered with sticky tape and newspaper.

Cover threads and the like on the object to be sprayed.

It is advisable to carry out a trial spraying onto cardboard or a similar surface to find the most suitable spray

gun adjustments.

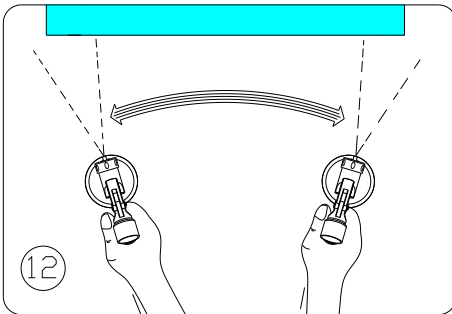
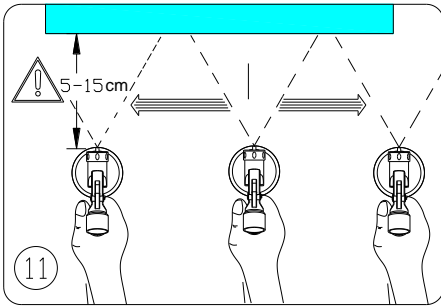

Important: start spraying outside the surface to be sprayed and avoid stopping on the surface.

Right (fig.11)

Always hold the spray gun at an even distance of approx. 5-15cm from the object to be sprayed. Move the spray gun evenly across or up and down, depending on the adjusted spraying effect. An even movement of the spray gun will give a uniform surface quality

Wrong (fig.12)

**Excessive paint mist formation
uneven surface finish**

If coating material builds up on the nozzle (2) and air cap (1) clean both parts with solvent or water.

Breaks in work

- Turn off device.
- Place spray gun in spray gun holder.

Closing down and cleaning

1. Turn off device. Open trigger so that the coating material in spray gun runs back into the container.
2. Unscrew the container. Return remaining coating material into the material can.
3. Clean the container and ascending pipe with a brush.
4. Fill the container with solvent or water.

Screw container back in place.

Only use solvent with a flash point of over 21° C

Turn on device and spray the solvent or water into a container.

If a tube is not used, some solvent or water will be deposited outside the container.

This is due to the high air volume.

5. Repeat the above procedure until clear solvent or water comes out of the nozzle.
6. Turn off device.
7. Then completely empty the container. Always keep the container seal free of coating material and check for damage.
8. Clean the outside of the spray gun and container with a cloth soaked in solvent or water.
9. Unscrew the union nut. Remove air cap .Clean the air cap and nozzle with brush and solvent or water .

Note:

Never clean the nozzle or air hole of the spray gun with sharp metallic objects .

Troubleshooting

Problem	Cause	Remedy
No coating material is coming out of the nozzle	The nozzle is blocked.	Clean
	The ascending pipe is blocked.	Clean
	The small hole in the ascending pipe is blocked.	Clean
	Material adjustment screw turned too far to the left (-).	Turn to the right (+)
	The ascending pipe is loose.	Tighten the pipe
	No pressure is built up in the container.	Tighten container
The coating material drips from the nozzle	The nozzle is loose.	Tighten
	The nozzle is worn.	Change
	Build up of coating material in the air cap and nozzle.	Clean

Spray too coarse	Coating material has a too high viscosity Too much material. Material adjustment screw turned too far to the right(+). Nozzle dirty. Air filter very dirty. Not enough pressure built up in container.	Dilute Turn material adjustment screw to the left (-) Turn to the left (-) Clean Change Tighten container
The spray jet pulses	Coating material in container is running out. The small hole in the ascending pipe is blocked Air filter very dirty.	Refill Clean Change
Run in the coating material	Too much coating material applied	Turn the material adjustment screw to the left (-)
Too much coating material mist (overspray)	The distance to the object to be sprayed is too large. Too much coating material applied	Reduce spraying distance Turn material adjustment screw to the left (-)