

**OPERATING INSTRUCTIONS / USER MANUAL**

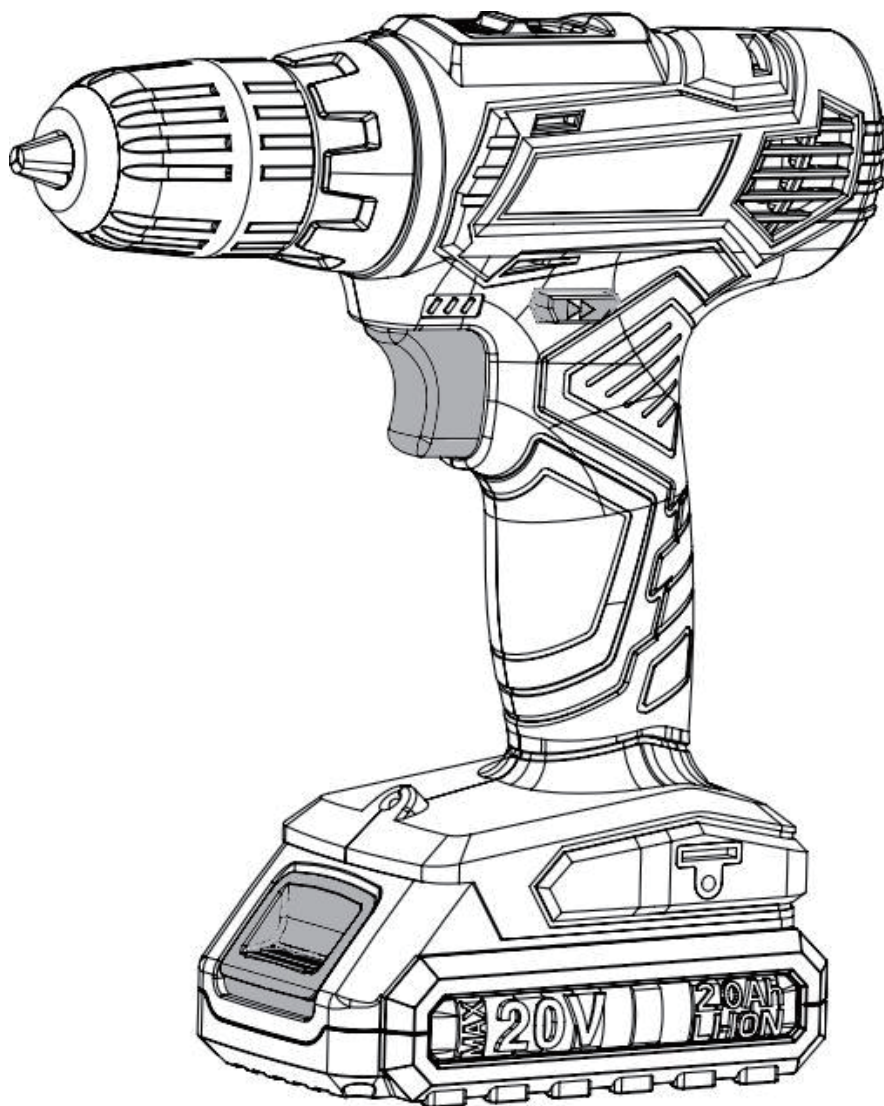

**DANGER! Read all safety regulations and instructions. Keep all safety regulations and instructions in a safe place for future use.**



**2025**

E&OE Please Note that details and specifications contained herein, are correct at the time of publishing. Adendorff reserve the right to change specifications at any time without prior notification.

Model: IDRILC-001

**CORDLESS DRILL DRIVER**

## **IMPORTANT SAFETY INFORMATION**

**Thank you for purchasing this quality product. We want to help you get the best results from your new equipment and to operate it safely.**

**This manual contains the information on how to do that; please read it carefully. You will need this manual for the safety warnings and precautions, operating, maintenance and cleaning procedures, parts list and assembly diagram. Keep your invoice with this manual. Write the invoice number on the inside of the front cover. Keep this manual and invoice in a safe and dry place for future reference.**

**This manual should be considered a permanent part of the product and should remain with it if it is resold.**

## **SAFETY PRECAUTIONS**

**Your safety and the safety of those around you are of utmost importance. This manual includes essential safety messages—please read them carefully to ensure proper use and avoid potential hazards.**

**The failure to follow instructions may result in damage to your power tool, other property, or the environment.**

### **Product Information & Disclaimer**

**All details and specifications provided in this publication are based on the latest available product information at the time of printing.**

**We reserve the right to make updates at any time without prior notice or obligation.**

**Reproduction of any part of this manual is prohibited without written permission.**

**By following these safety guidelines, you can ensure the proper use of your equipment while protecting yourself, others, and your surroundings.**

## TECHNICAL SPECIFICATIONS

MODEL	IDRILC001
<b>BATTERY TYPE:</b>	Lithium-Ion
<b>CHUCK TYPE:</b>	Keyless
<b>CHUCK SIZE:</b>	10mm
<b>BATTERY VOLTAGE:</b>	DC 20V
<b>BATTERY CAPACITY:</b>	2.0Ah
<b>NO-LOAD RPM:</b>	0-400 RPM / 0-1400RPM
<b>MAX TORQUE:</b>	35Nm
<b>MAX CAPACITY IN WOOD:</b>	25mm
<b>MAX CAPACITY IN STEEL:</b>	10mm
<b>MAX CAPACITY IN MASONRY:</b>	10mm
<b>WEIGHT:</b>	1.33kg
<b>CONTINUOUS WORKING TIME:</b>	10 mins
<b>BATTERY CHARGING TIME:</b>	90 mins
<b>SUPPLIED IN:</b>	BMC
<b>INCLUDES:</b>	Two 2.0Ah/20V Batteries, 1 Charger

Please note that the accessories shown in this manual may either be included with the unit upon purchase or may not be available for sale or included at all. Additionally, certain key features depicted may not be standard. This manual is intended for reference purposes only.

## PART LIST

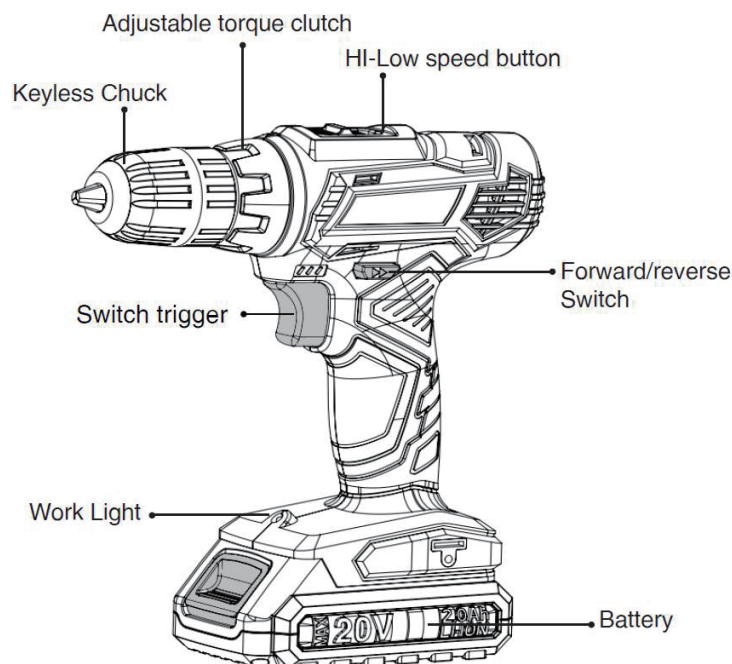

# GENERAL POWER TOOL SAFETY RULES

## **WARNING!**

**Read and save all safety warnings and instructions carefully. Failure to follow these warnings may result in electric shock, fire, or serious injury. Keep all warnings and instructions for future reference. The term “power tool” in these warnings applies to both mains-operated (corded) and battery-operated (cordless) tools.**

## **WORK AREA SAFETY**

- **Keep the work area clean and well-lit.** Cluttered or poorly lit spaces increase the risk of accidents.
- **Avoid operating power tools in explosive atmospheres.** Do not use tools in environments with flammable liquids, gases, or dust, as power tools generate sparks that could ignite these substances.
- **Keep children and bystanders at a safe distance while operating a power tool.** Distractions can lead to a loss of control, increasing the risk of injury.

## **ELECTRICAL SAFETY**

- **Ensure power tool plugs match the outlet.** Never modify the plug in any way or use adapter plugs with earthed (grounded) power tools. Properly matched, unmodified plugs and outlets reduce the risk of electric shock.
- **Avoid contact with earthed or grounded surfaces** such as pipes, radiators, ranges, and refrigerators. Contact with these surfaces increases the risk of electric shock.
- **Keep power tools away from rain or wet conditions.** Water entering a power tool significantly raises the risk of electric shock.
- **If using a power tool in a damp location is unavoidable,** ensure the power supply is protected by a **Ground Fault Circuit Interrupter (GFCI)**. A GFCI reduces the risk of electric shock in such conditions.

## **PERSONAL SAFETY**

- **Stay alert and focused.** Always pay attention to what you are doing and use common sense when operating a power tool. Avoid using power tools if tired or under the influence of drugs, alcohol, or medication. A moment of inattention can result in serious personal injury.
- **Use appropriate personal protective equipment.** Always wear eye protection, and use additional protective equipment such as a dust mask, non-skid safety shoes, a hard hat, or hearing protection, depending on the conditions. These measures reduce the risk of injury.
- **Prevent unintentional starting.** Ensure the switch is in the OFF position before connecting the tool to a power source, attaching a battery pack, picking up, or carrying the tool. Carrying tools with your finger on the switch or connecting power while the tool is on increases the risk of accidental activation.
- **Remove all adjusting keys or wrenches before turning on the tool.** Leaving these attached to rotating parts can cause serious personal injury.
- **Maintain proper footing and balance.** Avoid overreaching, and always keep a stable stance to retain control of the tool in unexpected situations.
- **Dress appropriately.** Avoid wearing loose clothing or jewellery, and ensure long hair is tied back. Keep hair, clothing, and gloves away from moving parts to prevent entanglement.
- **Use dust extraction and collection systems if available.** Properly connecting and using these systems helps reduce dust-related hazards.

## POWER TOOL USE AND CARE

- **Use the correct tool for the job.** Do not force the power tool to perform tasks it is not designed for. The appropriate power tool will complete the task more efficiently and safely when used as intended.
- **Ensure proper operation of the switch.** Do not use the power tool if the switch does not properly turn it on and off. A tool that cannot be controlled via the switch is hazardous and should be repaired before use.
- **Disconnect the power source before adjustments.** Always unplug the Tool or remove the battery pack before adjusting, changing accessories, or storing the tool. This precaution prevents accidental activation.
- **Store tools securely and out of reach of children.** Keep idle power tools in a safe location, away from children and individuals unfamiliar with their operation. Tools in the hands of untrained users can be dangerous.
- **Maintain tools.** Regularly inspect power tools for misalignment, binding of moving parts, breakage, or any condition that may affect their performance. Damaged tools should be repaired before use, as poorly maintained tools are a common cause of accidents.
- **Keep cutting tools sharp and clean.** Properly maintained and sharp cutting edges reduce the likelihood of binding and make the tool easier to control.
- **Follow the tool's instructions and intended use.** Use the power tool, accessories, and bits according to the provided instructions and the conditions of the task. Using tools for unintended applications can lead to hazardous situations.

## BATTERY TOOL USE AND CARE

- **Recharge only with the charger specified by the manufacturer.** Using a charger designed for a different battery pack may pose a risk of fire or damage to the battery.
- **Use designated battery packs.** Operate power tools only with the specific battery packs recommended by the manufacturer. Using other battery packs may result in injury or fire.
- **Store battery packs safely.** When not in use, keep the battery pack away from metal objects such as paper clips, coins, keys, nails, or screws. These items can create a connection between terminals, potentially causing burns or a fire.
- **Handle leaking batteries with care.** Under abusive conditions, liquid may leak from the battery:
  - Avoid contact with the liquid.**
    - If accidental contact occurs, flush the area with water.
    - If the liquid enters the eyes, rinse thoroughly with clean water for at least 10 minutes and seek medical attention.
  - Battery liquid may cause irritation or burns.

## SERVICE

- **Use qualified service professionals.** Always have power tools serviced by a qualified repair technician at Adendorff Machinery Mart [www.adendorff.co.za](http://www.adendorff.co.za), ensuring that only identical replacement parts are used. This guarantees the safety and performance of the tool.
- **Adhere to maintenance guidelines.** Follow the manufacturer's instructions for lubrication and accessory changes to maintain the tool's functionality and longevity.
- **Maintain cleanliness.** Keep handles and external surfaces dry, clean, and free from oil and grease. A clean tool provides better grip and reduces the risk of slipping during use.

# SAVE THESE INSTRUCTIONS

**These safety instructions will help ensure safe and effective operation of the tool.**

## **WARNING**

- **DO NOT** let comfort or familiarity with the product (gained from repeated use) replace strict adherence to safety rules for the subject product. **MISUSE** or failure to follow the safety rules stated in this instruction manual may cause serious personal injury.
- It's essential to remain vigilant and prioritize safety every time the tool is used, regardless of the level of experience. Always follow the instructions and safety guidelines to avoid accidents and injuries.

# CORDLESS DRILL/SCREWDRIVER SAFETY

## **WARNING!**

- **Use insulated gripping surfaces.** Always hold the power tool by its insulated gripping surfaces when performing operations where the fastener may contact hidden wiring or its own cord. Contact with a "live" wire may energize exposed metal parts, resulting in electric shock.
- **Ensure stable footing.** Maintain a firm stance and ensure that no one is below the work area when using the tool at elevated heights.
- **Hold the tool securely.** Grip the tool firmly during operation to maintain control.
- **Keep hands clear of rotating parts.** Avoid contact with any moving components to prevent injury.
- **Operate the tool only when hand-held.** Never leave the tool running unattended. Always switch it off after use.
- **Avoid contact with hot components.** The drill bit and workpiece may become extremely hot after operation. Allow sufficient cooling time before handling them to avoid burns.
- **Take precautions with hazardous materials.** Some materials may contain toxic chemicals. Follow the material supplier's safety data sheets (SDS) to prevent dust inhalation and skin contact. Use appropriate personal protective equipment (PPE).

## **WARNING!**

**Do not allow comfort or familiarity with the product from repeated use to override strict adherence to safety rules.** Failure to follow the safety guidelines in this manual may result in serious personal injury.

## IMPORTANT SAFETY INSTRUCTIONS FOR BATTERY CARTRIDGE

- **Read all instructions and cautionary markings.** Before using the battery cartridge, carefully review the instructions and safety warnings provided for the:
  - Battery charger
  - Battery
  - Product using the battery
- **Do not disassemble the battery cartridge.** Disassembly can result in safety hazards or damage.
- **Discontinue use if operating time shortens significantly.** If the battery's operating time becomes excessively shorter, stop using it immediately. Continued operation may lead to overheating, burns, or even an explosion.
- **Handle electrolyte exposure with care.** If electrolyte comes into contact with your eyes:
  - Rinse them thoroughly with clear water for at least 10 minutes.
  - Seek medical attention immediately. Electrolyte can cause severe irritation or potential loss of eyesight.

### DO NOT SHORT THE BATTERY CARTRIDGE

- **Avoid contact with terminals.** Do not touch the terminals of the battery cartridge with any conductive material.
- **Store the battery safely.** Do not store the battery cartridge in containers with other metal objects, such as nails, coins, or screws, to prevent accidental short circuits.
- **Protect from moisture.** Keep the battery cartridge away from water or rain. A short circuit caused by exposure to moisture can result in a large current flow, overheating, burns, or even battery failure.
- **Store in proper conditions.** Do not store the tool or battery cartridge in locations where the temperature may exceed 50°C (122°F).
- **Do not incinerate.** Never burn the battery cartridge, even if it is severely damaged or completely worn out. Incineration can cause the battery to explode.
- **Handle with care.** Avoid dropping or striking the battery cartridge to prevent internal damage.
- **Inspect before use.** Do not use a damaged battery cartridge under any circumstances.

### TIPS FOR MAINTAINING MAXIMUM BATTERY LIFE

- **Charge before complete discharge.** Stop using the tool and recharge the battery cartridge as soon as reduced power is noticed. Avoid fully depleting the battery to prolong its lifespan.
- **Do not overcharge.** Avoid recharging a fully charged battery cartridge. Overcharging can reduce the battery's service life.
- **Charge within the recommended temperature range.** Ensure the battery cartridge is charged in an environment with a temperature between 10°C - 40°C (50°F - 104°F). Allow the battery cartridge to cool down if it is hot before recharging.

## LIGHTING UP THE FRONT LAMP

### CAUTION:

- Do not look directly at the light or the source of light.
- To light up the lamp, pull the switch trigger. The lamp remains lit while the switch trigger is pulled.

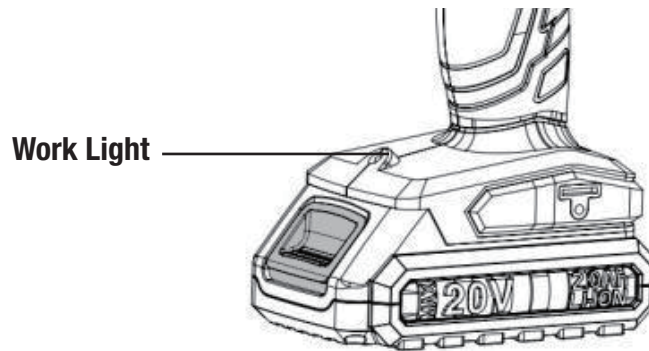

### NOTE:

Use a dry cloth to wipe dirt off the lens of the lamp. Be careful not to scratch the lens, as this may lower illumination.

## REVERSING SWITCH ACTION

This tool has a reversing switch to change the direction of rotation.

**For clockwise rotation:** Depress the reversing switch lever from the Right side.

**For counterclockwise rotation:** Depress the reversing switch lever from the Left side.

**Neutral position:** When the reversing switch lever is in the neutral position, the switch trigger is locked and cannot be pulled.

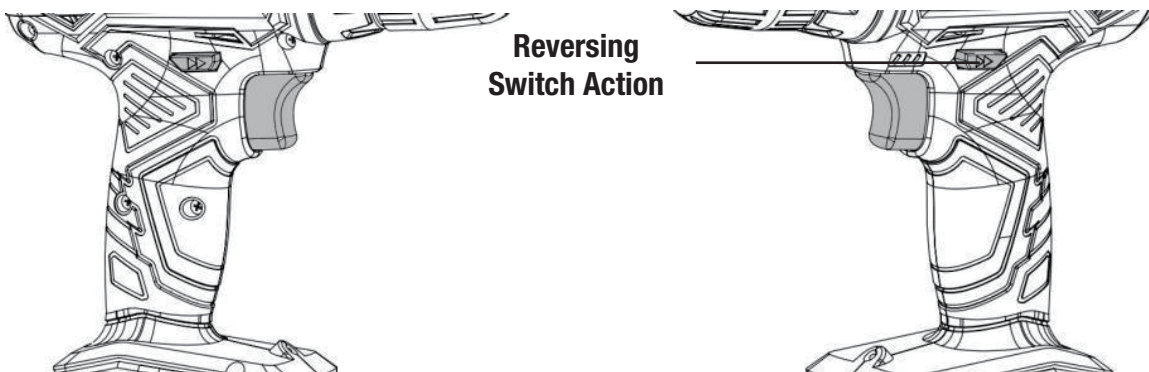

## FUNCTIONAL DESCRIPTION

**CAUTION:** Always ensure the tool is switched off and the battery cartridge is removed before adjusting or checking the function on the tool.

## INSTALLING OR REMOVING BATTERY CARTRIDGE

- **To remove the battery cartridge:** Slide the red button on the front of the cartridge and carefully withdraw it from the tool.
- **To insert the battery cartridge:** Align the tongue of the battery cartridge with the groove in the tool's housing. Slide the cartridge into place, ensuring it is inserted all the way until it locks in with a distinct click.
- **Avoid using force:** If the battery cartridge does not slide in easily, it is not aligned correctly. Check the alignment and try again.

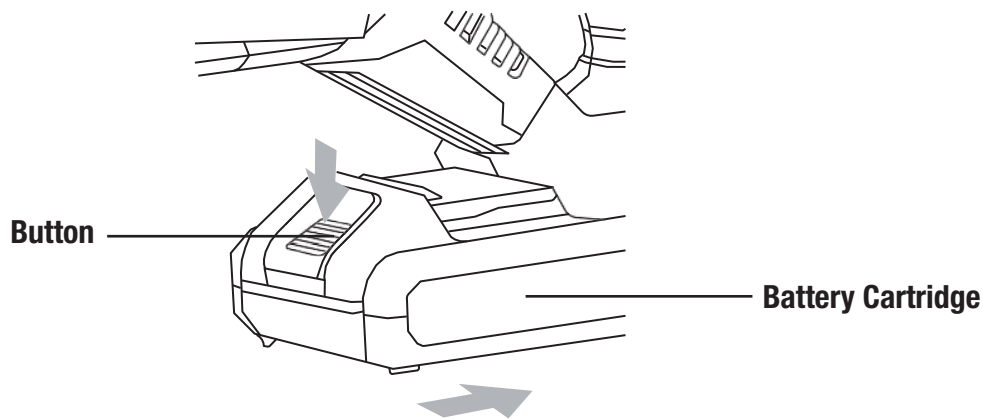

## BATTERY CHARGER OPERATION

**Power off before connecting.** Ensure the power source switch is turned **OFF** before plugging in the battery charger.

**Review the instruction manual.** Familiarize yourself with the entire manual before beginning any operation.

**Insert the battery correctly.** Align the terminals on the battery with those on the charger and slide the battery into place. It will lock securely with an audible click!

**Plug in the battery charger** then turn **ON** the power source

**The charge state lights will indicate the following:**

**SOLID RED = Charging**

**SOLID GREEN = Fully Charged**

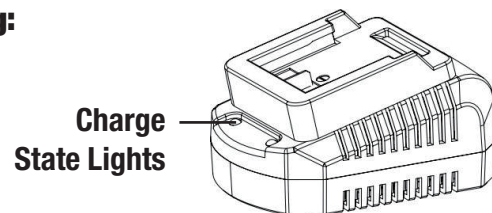

### NOTE:

**To remove the battery:** Press the **Battery Release Button** while gently pulling the battery away from the charger.

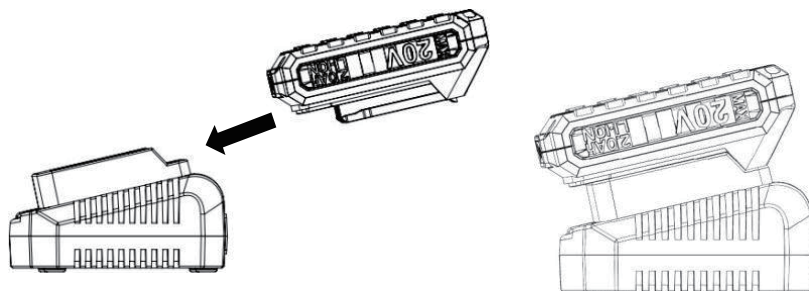

## SWITCH ACTION

### CAUTION:

- **Check the switch trigger.** Before inserting the battery cartridge into the tool, ensure the switch trigger functions correctly and returns to the **OFF** position when released.
- **Verify rotation direction.** Always confirm the tool's direction of rotation before beginning operation.
- **Use the reversing switch correctly.** Only activate the reversing switch. After the tool has come to a complete stop, changing the direction while the tool is running may cause damage.
- **Set to neutral when idle.** When the tool is not in use, always place the reversing switch lever in the neutral position to prevent accidental activation.

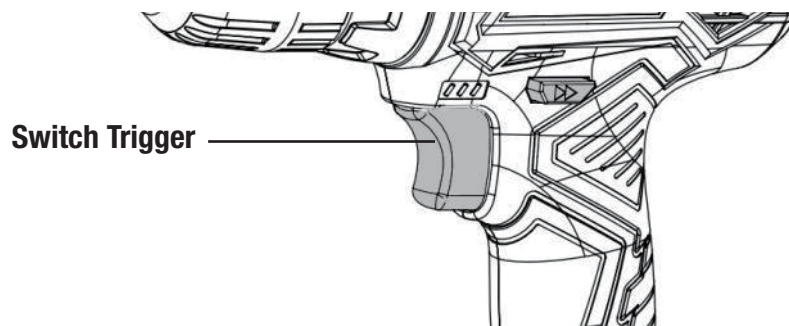

## SPEED CHANGE

- **Switch off the tool.** Before changing the speed, ensure the tool is turned off.
- **Adjust the speed change lever:**
  - Slide the lever to the «2» side for high speed.
  - Slide the lever to the «1» side for low speed.
- **Confirm the position:** Ensure the speed change lever is fully set to the desired position before resuming operation.
- **Use the appropriate speed:** Select the speed setting that best suits the specific requirements of your task.

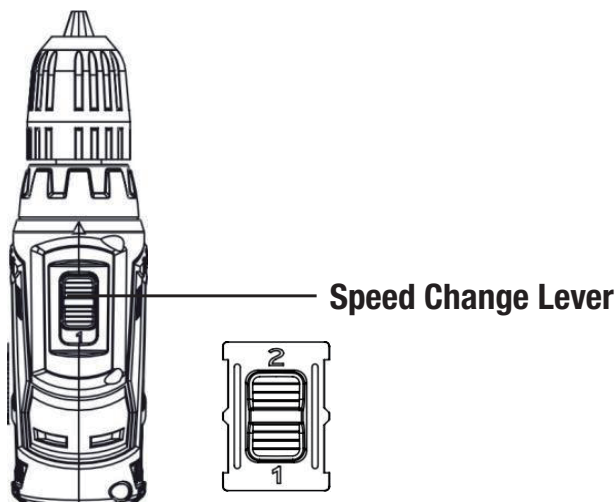

### CAUTION:

- **Set the lever fully:** Always ensure the speed change lever is completely set to either the «1» side (low speed) or «2» side (high speed). Operating the tool with the lever positioned halfway between settings may cause damage to the tool.
- **Avoid adjusting while running:** Never use the speed change lever while the tool is running. Doing so can result in damage to the tool's internal components.

## ELECTING THE ACTION MODE

**CAUTION:** Always set the ring correctly to the desired mode mark. Operating the tool with the ring positioned halfway between mode marks may damage the tool.

- **Action Mode Changing Ring**
- **Adjusting Ring**
- **Graduation**
- **Arrow**

This tool has three action modes:

- **Drilling Mode (rotation only)**
- **Hammer Drilling Mode (rotation with hammering)**
- **Screwdriving Mode (rotation with clutch)**

Select the appropriate mode for the work. Turn the action mode changing ring and align the selected mark with the arrow on the tool body.

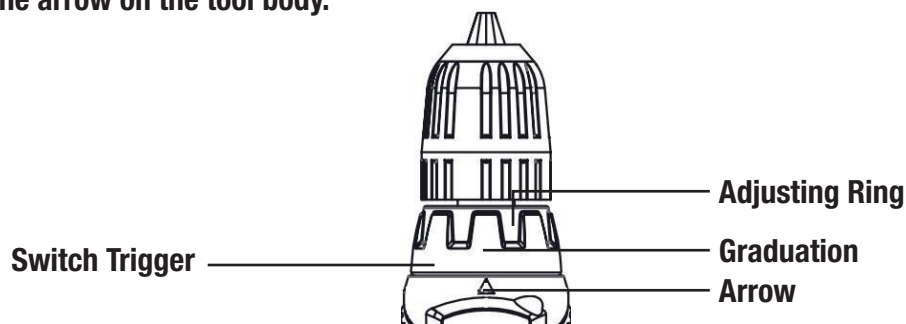

## ADJUSTING THE FASTENING TORQUE

The fastening torque can be adjusted in 18 steps by turning the adjusting ring, so its graduations align with the pointer on the tool body. The fastening torque is minimum when the number "1" is aligned with the pointer and maximum when the highest marking is aligned.

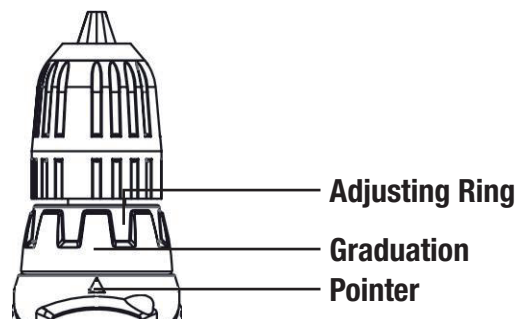

## ASSEMBLY

**CAUTION:**

Always ensure the tool is switched off and the battery cartridge is removed before carrying out any work on the tool.

## INSTALLING OR REMOVING DRIVER BIT OR DRILL BIT

- Turn the sleeve counterclockwise to open the chuck jaws.
- Place the bit in the chuck as far as it will go, then turn the sleeve clockwise to tighten the chuck.
- To remove the bit, turn the sleeve counterclockwise.

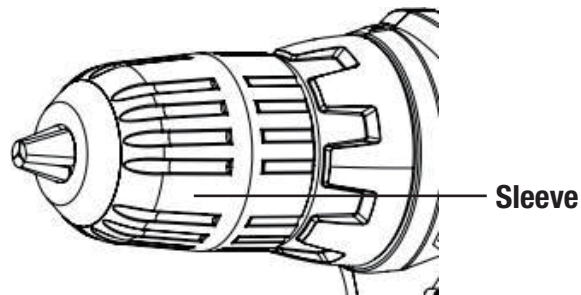

**NOTE:** When driving wood screws, pre-drill pilot holes to make driving easier and to prevent splitting of the workpiece. See the chart for recommended sizes.

NOMINAL DIAMETER OF WOOD SCREW (MM)	RECOMMENDED SIZE OF PILOT HOLE (MM)
3.1	2.0~2.2
3.5	2.2~2.5
3.8	2.5~2.8
4.5	2.9~3.2
4.8	3.1~3.4
5.1	3.3~3.6
5.5	3.7~3.9
5.8	4.0~4.2
6.1	4.2~4.4

## OPERATION

### CAUTION:

- **Ensure secure placement:** Always insert the battery cartridge fully until it locks firmly into place.
- **Avoid improper installation:** If the cartridge is not securely locked, it may accidentally fall out of the tool, posing a risk of injury to you or others nearby.
- **Maintain control:** Hold the tool firmly with one hand on the grip and the other hand supporting the bottom of the battery cartridge to manage twisting action during operation.

## DRILLING OPERATION

- **Set the adjusting ring:** Turn the adjusting ring so that the pointer aligns with the appropriate marking for drilling.
  - **Drilling in wood:**  
Use wood drill bits equipped with a guide screw for the best results.  
The guide screw helps by pulling the bit into the workpiece making drilling more efficient.
  - **Prevent slipping:**  
Before starting, make an indentation at the drilling point using a centre-punch and hammer.  
Place the drill bit's point into the indentation before starting the drill.
  - **Drilling in metals:**  
Use a cutting lubricant to ease the drilling process and extend the life of the drill bit.
  - **Exceptions:**  
Drilling in iron and brass should be done dry without lubrication.
- CAUTION:**
- Avoid applying excessive pressure on the tool while drilling.
  - **Excessive force:**  
Does not increase drilling speed.  
Can damage the drill bit tip.  
Reduces overall tool performance.  
Shortens the tool's service life.
  - Allow the tool to perform at its designed pace for optimal results.

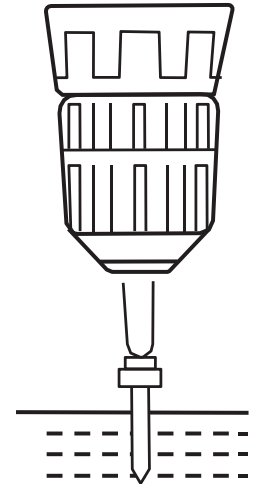

## SCREW DRIVING OPERATION

- CAUTION:**
- **Set the torque level:** Adjust the adjusting ring to the appropriate torque level for the task.
  - **Position the driver bit:** Place the point of the driver bit securely into the screw head.
  - **Apply steady pressure:** Hold the tool firmly and apply consistent pressure to the screw head.
  - **Start gradually:** Begin operating the tool at a slow speed, then gradually increase the speed as needed.
  - **Stop when the clutch engages:** Release the switch trigger immediately when the clutch cuts in to avoid over-tightening or damaging the screw.

- CAUTION:**
- **Ensure proper alignment:** Always insert the driver bit straight into the screw head. Misalignment can result in damage to both the screw and the bit.
  - **Be cautious during breakthrough:** Significant force is exerted when the bit breaks through the material. Hold the tool firmly and maintain control to prevent accidents.
  - **Removing a stuck bit:**  
Set the reversing switch to reverse rotation to back the bit out of the material.  
Be aware that the tool may back out abruptly. Hold it securely during this process.
  - **Secure small workpieces:** Use a vice or a similar hold-down device to keep small materials stable while working.
  - **Allow the tool to rest:** After continuous use until the battery is discharged, let the tool rest for 15 minutes before continuing with a freshly charged battery.

## GENERAL INSPECTION

- **BEFORE EACH USE:**  
Inspect the general condition of the tool thoroughly. Check for:
  - Leaking, swollen, or cracked battery pack.
  - Loose hardware.
  - Misalignment or binding of moving parts.
  - Cracked or broken parts.
  - Any other condition that may compromise safe operation.

## MAINTENANCE

### CAUTION:

- **Ensure safety before maintenance:** Always switch off the tool and remove the battery cartridge before performing any inspection or maintenance.
- **Avoid harmful substances:** Do not use petrol, diesel, benzene, thinner, alcohol, or similar substances for cleaning. These chemicals can cause discoloration, deformation, or cracks in the tool's materials.

### NOTE:

- **Authorized repairs only:** To ensure product safety and reliability, all repairs, maintenance, or adjustments should be performed exclusively by Adendorff Machinery Mart Authorized Service Centers.
- **Use genuine parts:** Always use Adendorff Machinery Mart-approved replacement parts to maintain the tool's performance and warranty coverage.

## STORAGE

- **Keep the tool stored in a dry, level area,** away from dampness, moisture, and rainfall.
- **Allow the tool to cool down completely before storing.**
- **Ensure the tool is clean and dry before storage.**
- **Store the tool in a position where it cannot be accidentally stepped on or moved,** especially to reach higher items.

### DO NOT:

- **Do not store the tool near an ignition source,** such as a wood stove, gas or electric heater, or any appliance with a pilot light.
- **Do not stack heavy or other items on top of the tool during storage.**

### IMPORTANT:

- **Store the tool out of reach of children or individuals unfamiliar with its operation.**
- **Avoid direct sunlight or extreme temperatures.** Store the tool indoors or in a safe, frost-free area

**PARTS LIST IDRILC-001**

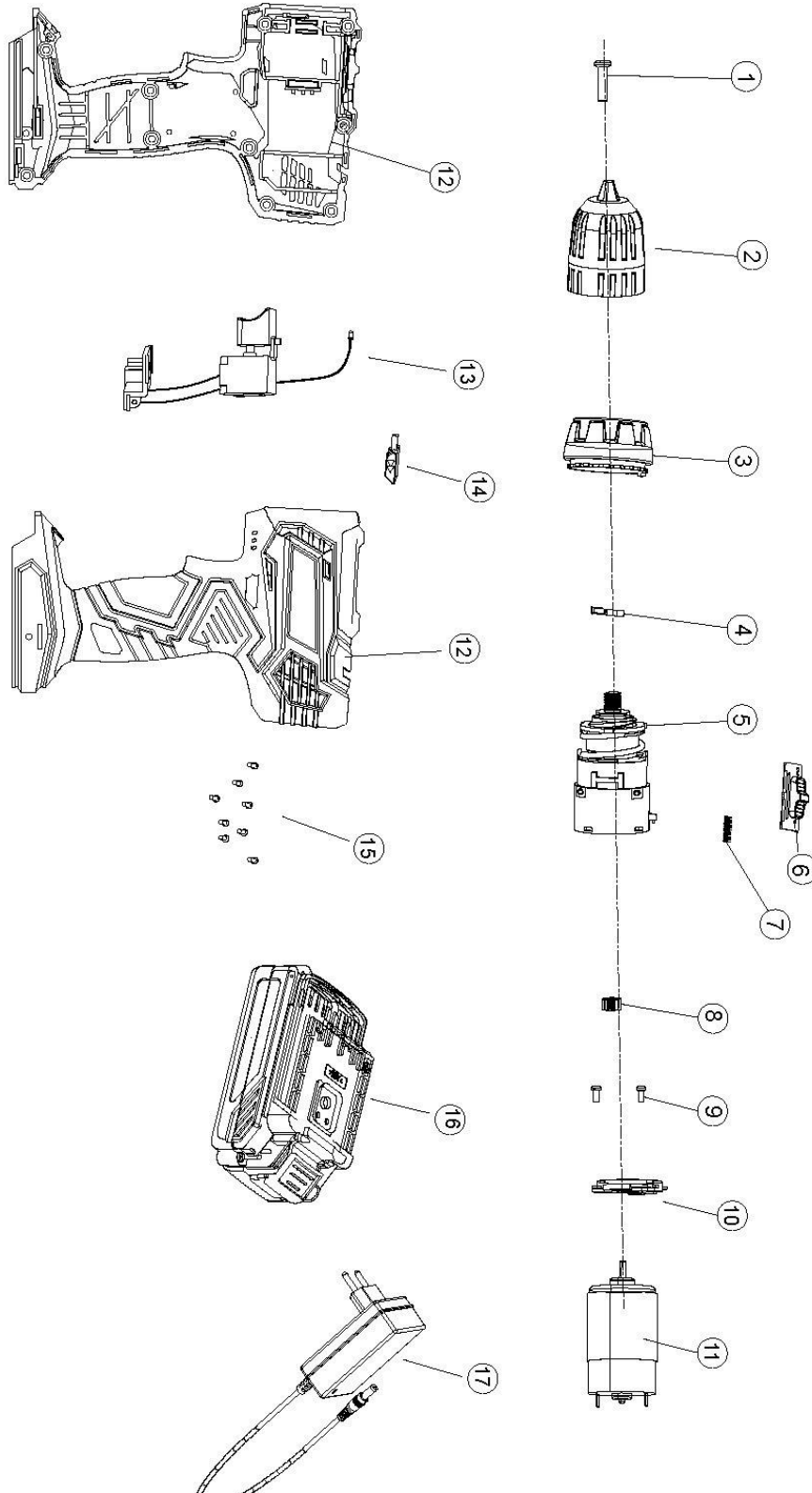

## PARTS LIST IDRILC-001

No.	Description	Quantity
1	Screw M5*23-LH	1
2	10mm chuck	1
3	Torque ring	1
4	Spring	1
5	Gear box assembly	1
6	Two speed push button	1
7	Spring	1
8	Motor gear	1
9	Screw M3*6	2
10	Motor cover plate	1
11	Motor	1
12	Left and right housing	1
13	Switch with light and connect pin assembly	1
14	Forward and reverse button	1
15	Screw ST3X12	8
16	Battery pack	1
17	Charger	1

## WARRANTY TERMS & CONDITIONS

### WARRANTY PERIOD

- This product is warranted for 12 months from the date of purchase by the first user.

### COVERAGE

- The warranty covers all material or production flaws, with exceptions:
  - Batteries and chargers
- Parts subject to normal wear (e.g., bearings, brushes, cables, plugs)
- Accessories (e.g., drill bits, saw blades)

### EXCLUSIONS

The warranty does not cover damage or defects from:

- Maltreatment, accidents, or alterations
- Inappropriate or negligent use of the tool
- Overloading, fluid permeation, excessive dust, or intentional damage
- Non-compliance with manual instructions, inexperienced assembly, lightning, or incorrect voltage

### LIABILITY

- Adendorff Machinery Mart disclaims liability for bodily injury resulting from improper tool use.

### REPAIRS

- Warranty repairs must be conducted by an authorized Adendorff Machinery Mart repair center. All stores have in-house service technicians.

### TRANSPORTATION COSTS

- Transportation costs for service are the customer's responsibility unless otherwise agreed in writing.

### WARRANTY CLAIMS

- All Warranty claims do not extend or restart the warranty period.
- Claims may be rejected if purchase cannot be verified or if product maintenance is found to be lacking.
- A 3-month (Three months) warranty applies to any repairs performed.

### MAINTENANCE AND PROOF OF PURCHASE

- Maintain the product as instructed (e.g., clean ventilation slots, service carbon brushes regularly).
- Retain the purchase receipt as proof of purchase date.

### RETURN CONDITIONS

- Return the product intact, in clean condition, and in its original blow-molded case (if applicable), along with proof of purchase.

**For full warranty details, visit [www.adendorff.co.za](http://www.adendorff.co.za). For assistance, contact the national call centre at 011 434 7000.**

**Supplied By**

