

OPERATING INSTRUCTIONS / USER MANUAL

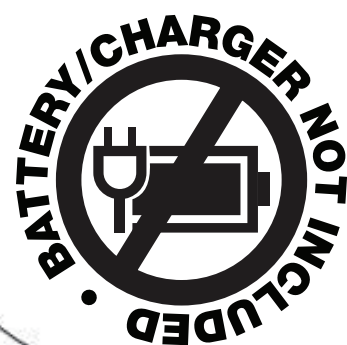

DANGER! Read all safety regulations and instructions. Keep all safety regulations and instructions in a safe place for future use.

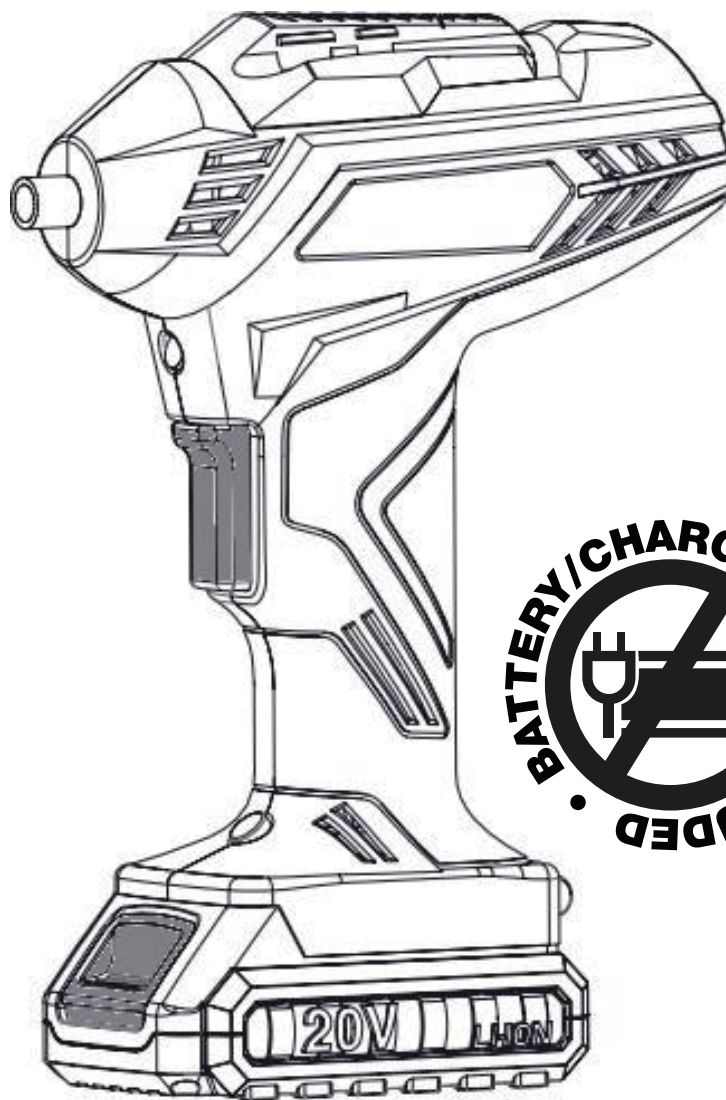

2025

E&OE Please Note that details and specifications contained herein, are correct at the time of publishing. Adendorff reserve the right to change specifications at any time without prior notification.

Model: ICOMPR-001

CORDLESS AIR COMPRESSOR

IMPORTANT SAFETY INFORMATION

Thank you for purchasing this quality product. We want to help you get the best results from your new equipment and to operate it safely.

This manual contains the information on how to do that; please read it carefully. You will need this manual for the safety warnings and precautions, operating, maintenance and cleaning procedures, parts list and assembly diagram. Keep your invoice with this manual. Write the invoice number on the inside of the front cover. Keep this manual and invoice in a safe and dry place for future reference.

This manual should be considered a permanent part of the product and should remain with it if it is resold.

SAFETY PRECAUTIONS

Your safety and the safety of those around you are of utmost importance. This manual includes essential safety messages—please read them carefully to ensure proper use and avoid potential hazards.

The failure to follow instructions may result in damage to your power tool, other property, or the environment.

Product Information & Disclaimer

All details and specifications provided in this publication are based on the latest available product information at the time of printing.

We reserve the right to make updates at any time without prior notice or obligation.

Reproduction of any part of this manual is prohibited without written permission.

By following these safety guidelines, you can ensure the proper use of your equipment while protecting yourself, others, and your surroundings.

TECHNICAL SPECIFICATIONS

MODEL	ICOMPR-001
BATTERY VOLTAGE:	DC 20V
BATTERY TYPE:	Lithium-Ion
psiMAX PRESSURE:	150psi / 10bar
WEIGHT:	0.79kg
INCLUDES:	1 Piece Valve Adapter
	1 Piece Inflatable Needle
	1 Piece Cone Adapter
	1 Piece Tracheal

Please note that the accessories shown in this manual may either be included with the unit upon purchase or may not be available for sale or included at all. Additionally, certain key features depicted may not be standard. This manual is intended for reference purposes only.

PART LIST

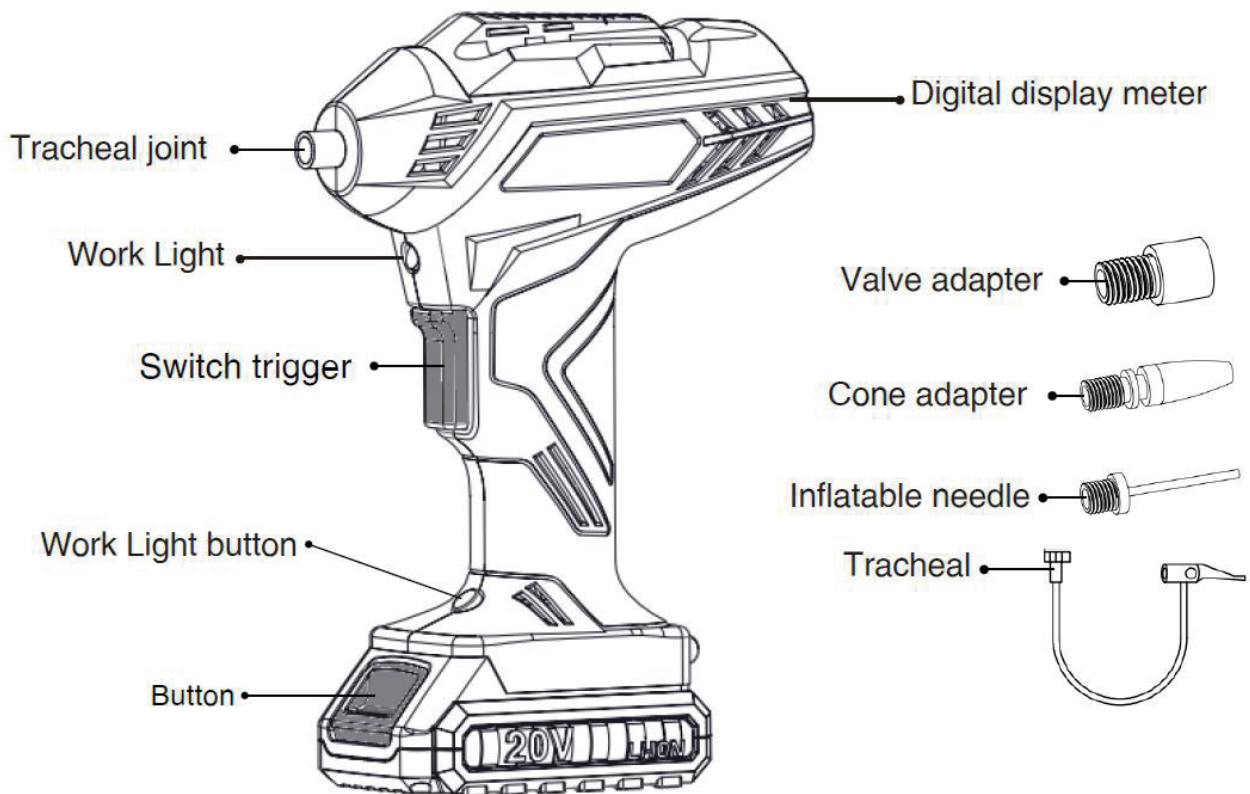

GENERAL POWER TOOL SAFETY RULES

WARNING!

Read and save all safety warnings and instructions carefully. Failure to follow these warnings may result in electric shock, fire, or serious injury. Keep all warnings and instructions for future reference. The term “power tool” in these warnings applies to both mains-operated (corded) and battery-operated (cordless) tools.

WORK AREA SAFETY

- **Keep the work area clean and well-lit.** Cluttered or poorly lit spaces increase the risk of accidents.
- **Avoid operating power tools in explosive atmospheres.** Do not use tools in environments with flammable liquids, gases, or dust, as power tools generate sparks that could ignite these substances.
- **Keep children and bystanders at a safe distance** while operating a power tool. Distractions can lead to a loss of control, increasing the risk of injury.

ELECTRICAL SAFETY

- **Ensure power tool plugs match the outlet.** Never modify the plug in any way or use adapter plugs with earthed (grounded) power tools. Properly matched, unmodified plugs and outlets reduce the risk of electric shock.
- **Avoid contact with earthed or grounded surfaces** such as pipes, radiators, ranges, and refrigerators. Contact with these surfaces increases the risk of electric shock.
- **Keep power tools away from rain or wet conditions.** Water entering a power tool significantly raises the risk of electric shock.
- **If using a power tool in a damp location is unavoidable,** ensure the power supply is protected by a **Ground Fault Circuit Interrupter (GFCI)**. A GFCI reduces the risk of electric shock in such conditions.

PERSONAL SAFETY

- **Stay alert and focused.** Always pay attention to what you are doing and use common sense when operating a power tool. Avoid using power tools if tired or under the influence of drugs, alcohol, or medication. A moment of inattention can result in serious personal injury.
- **Use appropriate personal protective equipment.** Always wear eye protection, and use additional protective equipment such as a dust mask, non-skid safety shoes, a hard hat, or hearing protection, depending on the conditions. These measures reduce the risk of injury.
- **Prevent unintentional starting.** Ensure the switch is in the OFF position before connecting the tool to a power source, attaching a battery pack, picking up, or carrying the tool. Carrying tools with your finger on the switch or connecting power while the tool is on increases the risk of accidental activation.
- **Remove all adjusting keys or wrenches before turning on the tool.** Leaving these attached to rotating parts can cause serious personal injury.
- **Maintain proper footing and balance.** Avoid overreaching, and always keep a stable stance to retain control of the tool in unexpected situations.
- **Dress appropriately.** Avoid wearing loose clothing or jewellery, and ensure long hair is tied back. Keep hair, clothing, and gloves away from moving parts to prevent entanglement.
- **Use dust extraction and collection systems if available.** Properly connecting and using these systems helps reduce dust-related hazards.

POWER TOOL USE AND CARE

- **Use the correct tool for the job.** Do not force the power tool to perform tasks it is not designed for. The appropriate power tool will complete the task more efficiently and safely when used as intended.
- **Ensure proper operation of the switch.** Do not use the power tool if the switch does not properly turn it on and off. A tool that cannot be controlled via the switch is hazardous and should be repaired before use.
- **Disconnect the power source before adjustments.** Always unplug the Tool or remove the battery pack before adjusting, changing accessories, or storing the tool. This precaution prevents accidental activation.
- **Store tools securely and out of reach of children.** Keep idle power tools in a safe location, away from children and individuals unfamiliar with their operation. Tools in the hands of untrained users can be dangerous.
- **Maintain tools.** Regularly inspect power tools for misalignment, binding of moving parts, breakage, or any condition that may affect their performance. Damaged tools should be repaired before use, as poorly maintained tools are a common cause of accidents.
- **Keep cutting tools sharp and clean.** Properly maintained and sharp cutting edges reduce the likelihood of binding and make the tool easier to control.
- **Follow the tool's instructions and intended use.** Use the power tool, accessories, and bits according to the provided instructions and the conditions of the task. Using tools for unintended applications can lead to hazardous situations.

BATTERY TOOL USE AND CARE

- **Recharge only with the charger specified by the manufacturer.** Using a charger designed for a different battery pack may pose a risk of fire or damage to the battery.
- **Use designated battery packs.** Operate power tools only with the specific battery packs recommended by the manufacturer. Using other battery packs may result in injury or fire.
- **Store battery packs safely.** When not in use, keep the battery pack away from metal objects such as paper clips, coins, keys, nails, or screws. These items can create a connection between terminals, potentially causing burns or a fire.
- **Handle leaking batteries with care.** Under abusive conditions, liquid may leak from the battery:
 - Avoid contact with the liquid.**
 - If accidental contact occurs, flush the area with water.
 - If the liquid enters the eyes, rinse thoroughly with clean water for at least 10 minutes and seek medical attention.
 - Battery liquid may cause irritation or burns.

SERVICE

- **Use qualified service professionals.** Always have power tools serviced by a qualified repair technician at Adendorff Machinery Mart www.adendorff.co.za, ensuring that only identical replacement parts are used. This guarantees the safety and performance of the tool.
- **Adhere to maintenance guidelines.** Follow the manufacturer's instructions for lubrication and accessory changes to maintain the tool's functionality and longevity.
- **Maintain cleanliness.** Keep handles and external surfaces dry, clean, and free from oil and grease. A clean tool provides better grip and reduces the risk of slipping during use.

CORDLESS AIR COMPRESSOR SAFETY

- **Secure Connections:**
When inflating, tightly connect the inflation clamp, adapter, and valve. Failure to secure these may result in damage to the inflatable object, hose, clamp, or adapter, and can lead to injury.
- **Slowly Release Air Pressure:**
When removing the hose after inflation, hold the inflation object, hose, and inflation clamp securely, as the adapter may rebound due to exhaust pressure, potentially causing injury.
- **Observe Maximum Inflation Pressure:**
Do not exceed the maximum air pressure that the inflatable object can withstand.
Exceeding this limit may result in damage to the tool, inflatable objects, nozzles, or adapters, and can cause injury.
Ensure that the inflation pressure does not exceed the tool's maximum inflation pressure to prevent swelling or cracking of the inflatable object or tool.
- **Use Approved Inflatable Items Only:**
Only inflate items specified by the manufacturer, such as tyres, sports balls, or small floats. Inflating non-designated items may damage the object and cause injury.
- **Inspect Before Inflating:** Check the condition of the barometer, tools, and inflatable object for any air leaks. Failure to check can lead to equipment damage or personal injury.
- **Proper Carrying:** Always carry the tool by its handle. Do not hold or pull by the hose, as this may damage the tool and cause injury.
- **Measure Air Pressure Accurately:** After inflation, use reliable measuring equipment to confirm air pressure. The built-in pressure gauge is for reference only.
- **Limit Continuous Use:** After 10 minutes of continuous use, allow the tool to cool down for 5 minutes. Exceeding recommended usage time may result in tool damage and injury.
- **Avoid Dusty and Sandy Surfaces:** Do not use the tool on surfaces covered with sand or dust, as foreign objects can enter the tool and cause malfunctions.
- **Do Not Direct Hose Outlet Toward Dust:** Avoid pointing the hose outlet toward dust or similar substances, as this can disperse particles into the air, risking personal injury.
- **Avoid Inflating Large-Capacity Items:** Inflating large items may cause the tool to overheat, increasing the risk of burns.
- **Hot Parts Warning:** Do not touch the tool, hose, inflation clamps, or connectors immediately after inflation, as these parts may be extremely hot and can burn the skin.
- **Avoid Using with Wet Hands:** Do not use the tool if your hands are wet.
- **Ensure Hose Remains Untangled:** Prevent tangling or knotting of the hose, as this may cause imbalance and increase the risk of injury.
- **Detach Hose Before Operation:** Do not attempt to inflate an object or operate the tool before the hose has been removed from the inflatable object, as this can lead to unattended operation.
- **Do Not Use as a Breathing Apparatus:** This tool is not designed for use as a breathing apparatus.
- **Avoid Using Tool to Spray Chemicals:** Using this tool to spray chemicals can cause toxic gases to be inhaled, leading to lung injury.
- **Maintain Clearance During Operation:** Keep a minimum distance of 50 cm from walls or any obstacles that may obstruct airflow into ventilation openings.
- **Do Not Disassemble the Tool:** Disassembling the tool may void safety features and increase the risk of injury.
- **Use Only Approved Accessories:** Only use Kinway standard accessories. Using unapproved accessories may pose safety risks.

Inspect Tyres Before Inflation: Before inflating a tyre, ensure it has no scratches or cracks, as damaged tyres may burst during inflation, causing injury.

Stay Clear of Tyre Wall Range: When inflating a tyre, do not stand directly in front of the tyre wall to avoid potential injury in case of tyre failure.

WARNING!

Do not allow comfort or familiarity with this product, developed through repeated use, to replace strict adherence to the safety rules outlined in this manual. Misuse or failure to follow these safety rules may result in serious personal injury.

LIGHTING UP THE FRONT LAMP

CAUTION:

- Do not look directly at the light or the source of light.
- To light up the lamp, pull the switch trigger. The lamp remains lit while the switch trigger is pulled.

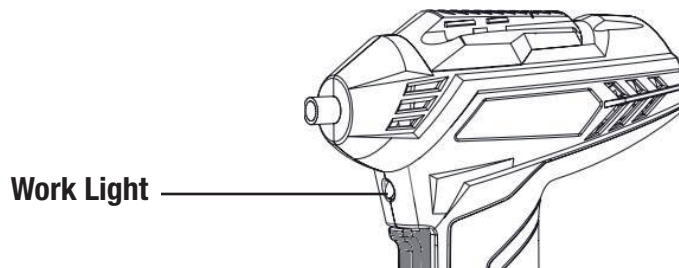

NOTE:

Use a dry cloth to wipe dirt off the lens of the lamp. Be careful not to scratch the lens, as this may lower illumination.

SWITCH ACTION

CAUTION:

- **Check the switch trigger.** Before inserting the battery cartridge into the tool, ensure the switch trigger functions correctly and returns to the **OFF** position when released.
- **Verify rotation direction.** Always confirm the tool's direction of rotation before beginning operation.
- **Use the reversing switch correctly.** Only activate the reversing switch. After the tool has come to a complete stop, changing the direction while the tool is running may cause damage.
- **Set to neutral when idle.** When the tool is not in use, always place the reversing switch lever in the neutral position to prevent accidental activation.

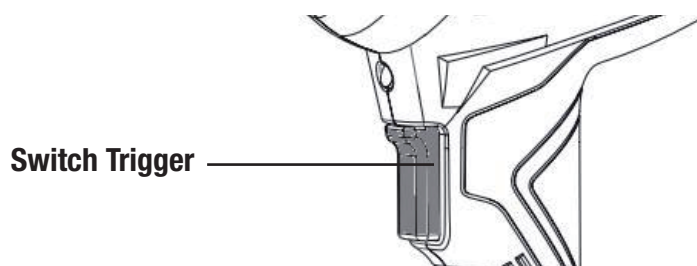

INSTALLING OR REMOVING BATTERY CARTRIDGE

- **To remove the battery cartridge:** Slide the red button on the front of the cartridge and carefully withdraw it from the tool.
- **To insert the battery cartridge:** Align the tongue of the battery cartridge with the groove in the tool's housing. Slide the cartridge into place, ensuring it is inserted all the way until it locks in with a distinct click.
- **Avoid using force:** If the battery cartridge does not slide in easily, it is not aligned correctly. Check the alignment and try again.

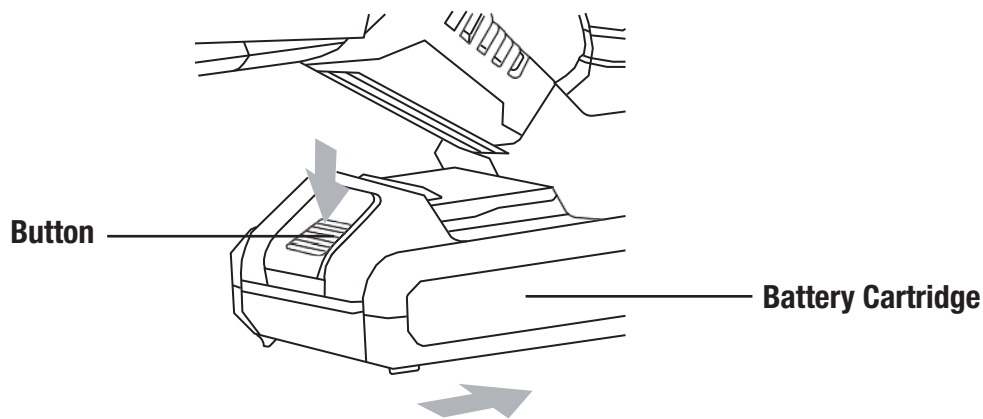

BATTERY CHARGER OPERATION

Power off before connecting. Ensure the power source switch is turned **OFF** before plugging in the battery charger.

Review the instruction manual. Familiarize yourself with the entire manual before beginning any operation.

Insert the battery correctly. Align the terminals on the battery with those on the charger and slide the battery into place. It will lock securely with an audible click!

Plug in the battery charger then turn **ON** the power source

The charge state lights will indicate the following:

SOLID RED = Charging

SOLID GREEN = Fully Charged

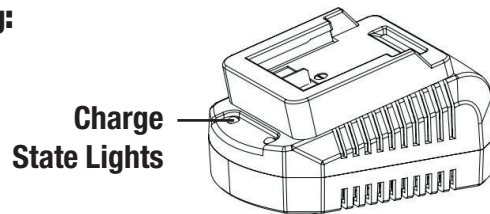

NOTE:

To remove the battery: Press the **Battery Release Button** while gently pulling the battery away from the charger.

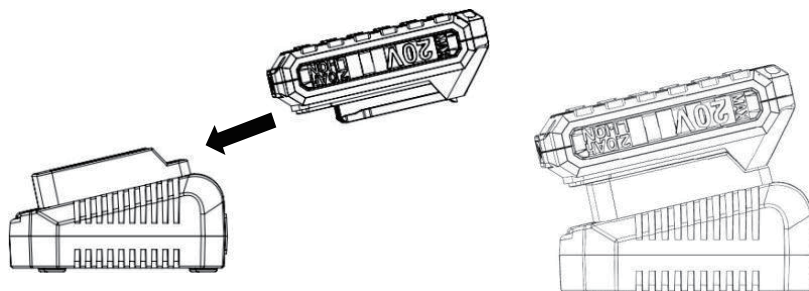

IMPORTANT SAFETY INSTRUCTIONS FOR BATTERY CARTRIDGE

- **Read all instructions and cautionary markings.** Before using the battery cartridge, carefully review the instructions and safety warnings provided for the:

Battery charger	Battery	Product using the battery
-----------------	---------	---------------------------
- **Do not disassemble the battery cartridge.** Disassembly can result in safety hazards or damage.
- **Discontinue use if operating time shortens significantly.** If the battery's operating time becomes excessively shorter, stop using it immediately. Continued operation may lead to overheating, burns, or even an explosion.
- **Handle electrolyte exposure with care.** If electrolyte comes into contact with your eyes:
 - Rinse them thoroughly with clear water for at least 10 minutes.
 - Seek medical attention immediately. Electrolyte can cause severe irritation or potential loss of eyesight.

DO NOT SHORT THE BATTERY CARTRIDGE

- **Avoid contact with terminals.** Do not touch the terminals of the battery cartridge with any conductive material.
- **Store the battery safely.** Do not store the battery cartridge in containers with other metal objects, such as nails, coins, or screws, to prevent accidental short circuits.
- **Protect from moisture.** Keep the battery cartridge away from water or rain. A short circuit caused by exposure to moisture can result in a large current flow, overheating, burns, or even battery failure.
- **Store in proper conditions.** Do not store the tool or battery cartridge in locations where the temperature may exceed 50°C (122°F).
- **Do not incinerate.** Never burn the battery cartridge, even if it is severely damaged or completely worn out. Incineration can cause the battery to explode.
- **Handle with care.** Avoid dropping or striking the battery cartridge to prevent internal damage.
- **Inspect before use.** Do not use a damaged battery cartridge under any circumstances.

TIPS FOR MAINTAINING MAXIMUM BATTERY LIFE

- **Charge before complete discharge.** Stop using the tool and recharge the battery cartridge as soon as reduced power is noticed. Avoid fully depleting the battery to prolong its lifespan.
- **Do not overcharge.** Avoid recharging a fully charged battery cartridge. Overcharging can reduce the battery's service life.
- **Charge within the recommended temperature range.** Ensure the battery cartridge is charged in an environment with a temperature between 10°C - 40°C (50°F - 104°F). Allow the battery cartridge to cool down if it is hot before recharging.

IMPORTANT CHARGING NOTES

- **Do not store in locations where the temperature may exceed 40°C:** Ensure that the tool is stored in a cool, dry place.
- **Charge only at ambient temperatures between 4°C and 40°C:** Charging outside this range can cause damage to the battery.
- **Charge only using the charger provided with the tool:** Other chargers may use different amperages that can damage or destroy the battery and/or tool.
- **Unplug charger before attempting to clean:** Always unplug the charger before cleaning to prevent electric shock or damage to the charger.
- **Do not immerse the charger in water or any other liquid:** Avoid getting the charger wet to prevent electric shock or damage.

GENERAL INSPECTION

- **BEFORE EACH USE:**
Inspect the general condition of the tool thoroughly. Check for:
 - Leaking, swollen, or cracked battery pack.
 - Loose hardware.
 - Misalignment or binding of moving parts.
 - Cracked or broken parts.
 - Any other condition that may compromise safe operation.

MAINTENANCE

CAUTION:

- **Ensure safety before maintenance:** Always switch off the tool and remove the battery cartridge before performing any inspection or maintenance.
- **Avoid harmful substances:** Do not use petrol, diesel, benzene, thinner, alcohol, or similar substances for cleaning. These chemicals can cause discoloration, deformation, or cracks in the tool's materials.

NOTE:

- **Authorized repairs only:** To ensure product safety and reliability, all repairs, maintenance, or adjustments should be performed exclusively by Adendorff Machinery Mart Authorized Service Centers.
- **Use genuine parts:** Always use Adendorff Machinery Mart-approved replacement parts to maintain the tool's performance and warranty coverage.

STORAGE

- **Keep the tool stored in a dry, level area,** away from dampness, moisture, and rainfall.
- **Allow the tool to cool down completely before storing.**
- **Ensure the tool is clean and dry before storage.**
- **Store the tool in a position where it cannot be accidentally stepped on or moved,** especially to reach higher items.

DO NOT:

- **Do not store the tool near an ignition source,** such as a wood stove, gas or electric heater, or any appliance with a pilot light.
- **Do not stack heavy or other items on top of the tool during storage.**

IMPORTANT:

- **Store the tool out of reach of children or individuals unfamiliar with its operation.**
- **Avoid direct sunlight or extreme temperatures. Store the tool indoors or in a safe, frost-free area**

PARTS LIST ICOMPR-001

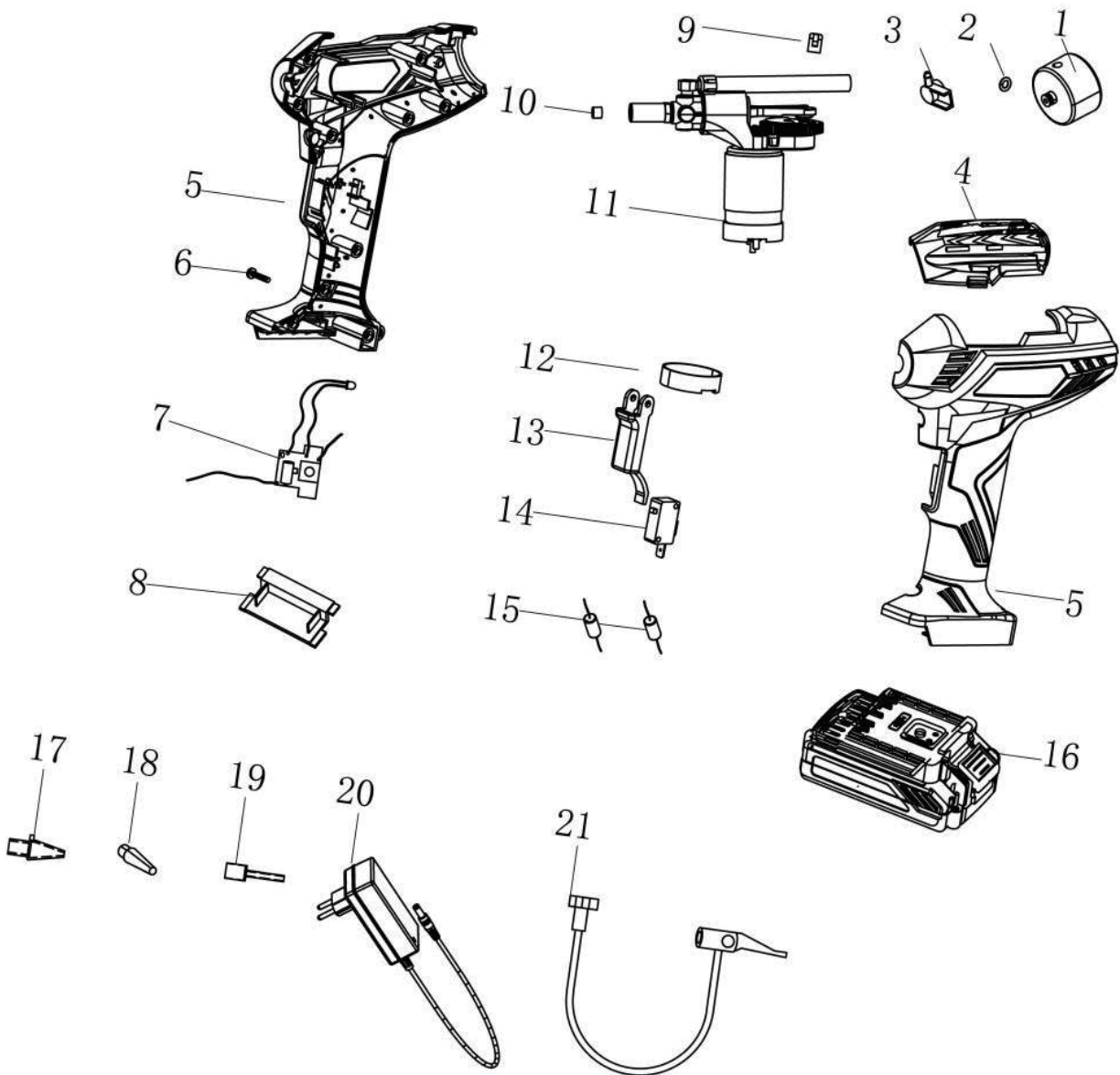

PARTS LIST ICOMPR-001

No.	Description
1	Dial Indicator
2	O Type Sealed Ring
3	Base Of The Pointer
4	Top Of The Cover
5	Body Housing
6	Cross Pan Head Tapping Screws
7	Lighting Switch Assembly
8	Contact Bracket
9	Clamp
10	Washer Of The Cylinder
11	Machine Core Components
12	Motor Lining
13	Switch The Trigger
14	Micro Switch
15	Inductor
16	Battery (Sold Separately)
17	Air Nozzle
18	Adaptor Nozzle For Motor-Cycles And Bicycles
19	Adapter Nozzle For Ball
20	Charger (Sold Separately)
21	Air Tube

WARRANTY TERMS & CONDITIONS

WARRANTY PERIOD

- This product is warranted for 12 months from the date of purchase by the first user.

COVERAGE

- The warranty covers all material or production flaws, with exceptions:
- Batteries and chargers
- Parts subject to normal wear (e.g., bearings, brushes, cables, plugs)
- Accessories (e.g., drill bits, saw blades)

EXCLUSIONS

The warranty does not cover damage or defects from:

- Maltreatment, accidents, or alterations
- Inappropriate or negligent use of the tool
- Overloading, fluid permeation, excessive dust, or intentional damage
- Non-compliance with manual instructions, inexperienced assembly, lightning, or incorrect voltage

LIABILITY

- Adendorff Machinery Mart disclaims liability for bodily injury resulting from improper tool use.

REPAIRS

- All Warranty repairs must be conducted by an authorized Adendorff Machinery Mart repair center. All stores have in-house service technicians.

TRANSPORTATION COSTS

- Transportation costs for service are the customer's responsibility unless otherwise agreed in writing.

WARRANTY CLAIMS

- All Warranty claims do not extend or restart the warranty period.
- Claims may be rejected if purchase cannot be verified or if product maintenance is found to be lacking.
- A 3-month (Three Months) warranty applies to any repairs performed.

MAINTENANCE AND PROOF OF PURCHASE

- Maintain the product as instructed (e.g., clean ventilation slots, service carbon brushes regularly).
- Retain the purchase receipt as proof of purchase date.

RETURN CONDITIONS

- Return the product intact, in clean condition, and in its original blow-molded case (if applicable), along with proof of purchase.

For full warranty details, visit www.adendorff.co.za. For assistance, contact the national call centre at 011 434 7000.

 **Kinway**

Supplied By

Adendorff
machinery mart