



www.adendorff.co.za

SR0UTR-002

ELECTRIC TRIMMER



ORIGINAL OPERATING INSTRUCTIONS

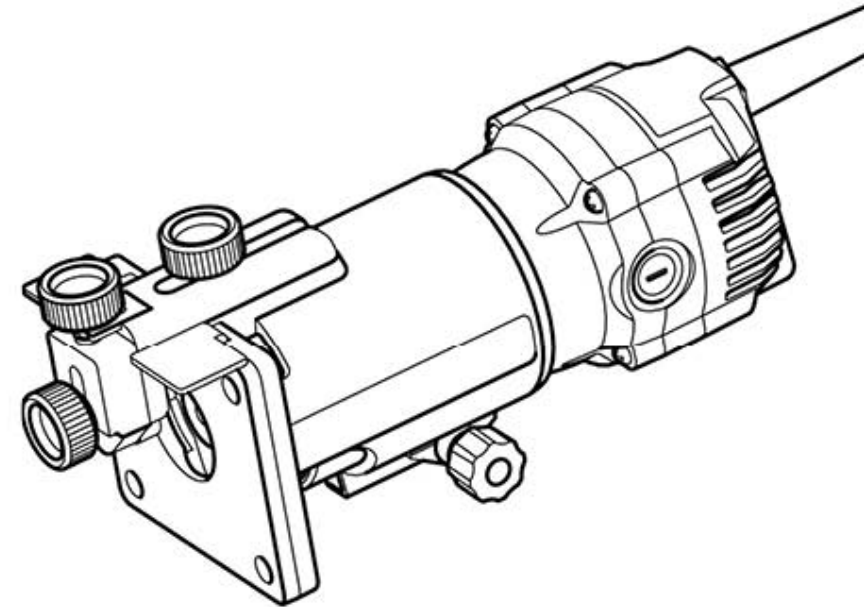

DANGER! Read all safety regulations and instructions.
Keep all safety regulations and instructions in a safe place for future use.



www.adendorff.co.za

ERBE Please Note that details and specifications contained herein are correct at the time of publishing. Adendorff reserves the right to change specifications at any time without prior notice.

COPYRIGHT ADENDORFF MACHINERY MART

GENERAL POWER TOOL SAFETY WARNINGS

(For All Power Tools)

⚠ WARNING! Read and understand all instructions. *Failure to follow all instructions listed below may result in electric shock, fire and/or serious personal injury.*

Save all warnings and instructions for future reference.

The term “power tool” in the warnings refers to your mains-operated (corded) power tool or battery-operated (cordless) power tool.

Work Area Safety

1. Keep work area clean and well lit. *Cluttered or dark areas invite accidents.*
2. Do not operate power tools in explosive atmospheres, such as in the presence of flammable liquids, gases, or dust. *Power tools create sparks which may ignite the dust or fumes.*
3. Keep children and bystanders away while operating a power tool. *Distractions can cause you to lose control.*

Electrical Safety

4. Power tool plugs must match the outlet. Never modify the plug in anyway. Do not use any adapter plugs with earthed (grounded) power tools. *Unmodified plugs and matching outlets will reduce risk of electric shock.*
5. Avoid body contact with earthed or grounded surfaces, such as pipes, radiators, ranges and refrigerators. *There is an increased risk of electric shock if your body is earthed or grounded.*
6. Do not expose power tools to rain or wet conditions. *Water entering a power tool will increase the risk of electric shock.*
7. Do not abuse the cord. Never use the cord for carrying, pulling or unplugging the power tool. Keep cord away from heat, oil, sharp edges or moving parts. *Damaged or entangled cords increase the risk of electric shock.*
8. When operating a power tool outdoors, use an extension cord suitable for outdoor use. *Use of a cord suitable for outdoor use reduces the risk of electric shock.*
9. If operating a power in a damp location is unavoidable, use a residual current device (RCD)

protected supply. *Use of an RCD reduces the risk of electric shock.*

NOTE: The term “residual current device (RCD)” may be replaced by the term “ground fault circuit interrupter (GFCI)” or “earth leakage circuit breaker (ELCB)”.

Personal Safety

10. Stay alert, watch what you are doing and use common sense when operating a power tool. Do not use a power tool while you are tired or under the influence of drugs, alcohol, or medication. *A moment of inattention while operating power tools may result in serious personal injury.*
11. Use personal protective equipment. Always wear eye protection. *Protective equipment such as dust mask, non-skid safety shoes, hard hat, or hearing protection used for appropriate conditions will reduce personal injuries.*
12. Prevent unintentional starting. Ensure the switch is in the off-position before connecting to power source and /or battery pack, picking up or carrying the tool. *Carrying power tools with your finger on the switch or energising power tools that have the switch on invites accidents.*
13. Remove any adjusting key or wrench before turning the tool on. *A wrench or a key left attached to a rotating part of the power tool may result in personal injury.*
14. Do not overreach. Keep proper footing and balance at all times. *This enables better control of the power tool in unexpected situations.*
15. Dress properly. Do not wear loose clothing or jewellery. Keep your hair, clothing, and gloves away from moving parts. *Loose clothes, jewellery or long hair can be caught in moving parts.*
16. If devices are provided for the connection of dust extraction and collection facilities, ensure these are connected and properly used. *Use of dust collection can reduce dust-related hazards.*

Power Tool Use and Care

17. Do not force the power tool. Use the correct power tool for your application. *The correct power tool will do the job better and safer at the rate for which it was designed.*

18. Do not use tool if switch does not turn it on or off. *Any power tool that cannot be controlled with the switch is dangerous and must be repaired.*
19. Disconnect the plug from the power source and/or the battery pack from the power tool before making any adjustments, changing accessories, or storing power tools. *Such preventive safety measures reduce the risk of starting the power tool accidentally.*
20. Store idle power tools out of the reach of children and do not allow persons unfamiliar with the power tool or these instructions to operate the power tool. *Power tools are dangerous in the hands of untrained users.*
21. Maintain power tools. Check for misalignment or binding of moving parts, breakage of parts and any other condition that may affect the power tool's operation. If damaged, have the power tool repaired before use. *Many accidents are caused by poorly maintained power tools.*
22. Keep cutting tools sharp and clean. *Properly maintained cutting tools with sharp cutting edges are less likely to bind and are easier to control.*
23. Use the power tool, accessories and tool bits etc. in accordance with these instructions, taking into account the working conditions and the work to be performed. *Use of the power tool for operations different from those intended could result in a hazardous situation.*

Service

24. Have your power tool serviced by a qualified repair person using only identical replacement parts. *This will ensure that the safety of the power tool is maintained.*

VOLTAGE WARNING:

Before connecting the machine to a power source (receptacle, outlet, etc.), be sure the voltage supplied is the same as that specified on the nameplate of the machine. A power source with voltage greater than that specified for the machine can result in **SERIOUS INJURY** to the user, as well as damage to the machine. If in doubt, **DO NOT PLUG IN THE MACHINE**. Using a power source with voltage less than nameplate rating is harmful to the motor.

SPECIFICATIONS

Rated Power Input	550 W
No-Load Speed	30000 r/min
Collet Chuck Capacity	6.35/6 mm
Net Weight	1.6 kg

※ Due to the continuing program of research and development, the specifications herein are subject to change without prior notice.

※ Specifications may differ from country to country..

ADDITIONAL SAFETY RULES

1. Hold tool by insulated gripping surfaces when performing an operation where the cutting tool may contact hidden wiring or its own cord. Contact with a “live” wire will make exposed metal parts of the tool “live” and shock the operator.
2. Wear hearing protection during extended period of operation.
3. Handle the bits very carefully.
4. Check the bit carefully for cracks or damage before operation. Replace cracked or damaged bit immediately.
5. Check that the tool is switched OFF before plugging it into the power supply.
6. Avoid cutting nails. Check the workpiece and remove all the nails, if there have, before operation.
7. Hold the tool firmly with both hands.
8. Keep hands away from rotating parts.
9. Make sure that the bit is not contacting the workpiece before the switch is turned on.
10. Before using the tool on an actual workpiece, let it run for a while. Watch for vibration or wobbling that could indicate improperly installed bit.
11. Be careful of the bit rotating direction and the feed direction.
12. Do not leave the tool running. Operate the tool only when hand-held.
13. Always switch off and wait for the bit come to a complete stop before removing the tool from workpiece.

14. Do not touch the bit immediately after operation; it may be extremely hot and could burn your skin.
15. Always lead the power supply cord away from the tool towards the rear.
16. Don't smear the tool base carelessly with thinner, gasoline, oil or the like. They may cause cracks on the tool base.
17. Draw attention to the need to use cutters of the correct shank diameter and suitable for the speed of the tool.
18. Some material contains chemicals which may be toxic. Take caution to prevent working dust inhalation and skin contact. Follow material supplier safety data.

SAVE THESE INSTRUCTIONS.

WARNING! MISUSE or failure to follow the safety rules stated in this instruction manual may cause serious personal injury.

INSTRUCTIONS FOR OPERATION

Installing or Removing the Bit

CAUTION:

- Always be sure that the tool is switched off and unplugged from the supply outlet before installing or removing the bit.
- Make sure to tighten the collect chuck after inserting the bit. Do not tighten the collect nut without inserting a bit, or the collect cone will break. Use the wrench supplied.

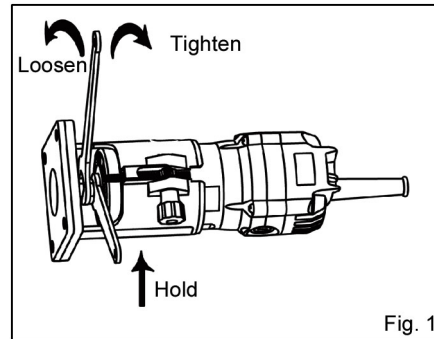

Fig. 1

Insert the bit all the way into the collect cone and tighten the collect nut securely with two wrenches. (Fig. 1)

To remove the bit, follow the installation procedure in reverse.

Adjusting Bit Protrusion

CAUTION:

Always be sure that the tool is switched off and unplugged before adjusting the bit protrusion.

To adjust the bit protrusion, loosen the adjusting screw and move the tool base up or down as desired. After adjusting, secure the screw. (Fig. 2)

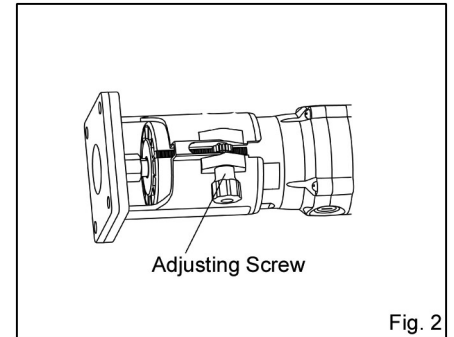

Fig. 2

Switch Action

CAUTION:

Before plugging in the tool, always be sure that the tool is switched off.

To start the tool, move the switch lever to the "1" position. To stop, move the switch lever to the "0" position. (Fig. 3)

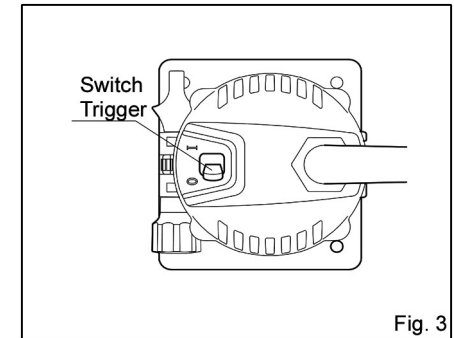

Fig. 3

Operation

CAUTION:

Since excessive cutting may cause overload of the motor or difficulty in controlling the tool, the depth of cut should not be more than 3 mm (1/8") at a pass when cutting grooves. When you wish to cut grooves more than 3 mm (1/8") deep, make several passes with progressively deeper bit settings.

Set the tool base upon the workpiece without the bit making any contact. Switch on and wait until the bit attains full speed. Move the tool forward over the workpiece surface, keeping the tool base flush and advancing smoothly until the cutting is complete.

When doing edge cutting, the workpiece surface should be on the left side of the bit in the feed direction. (Fig. 4)

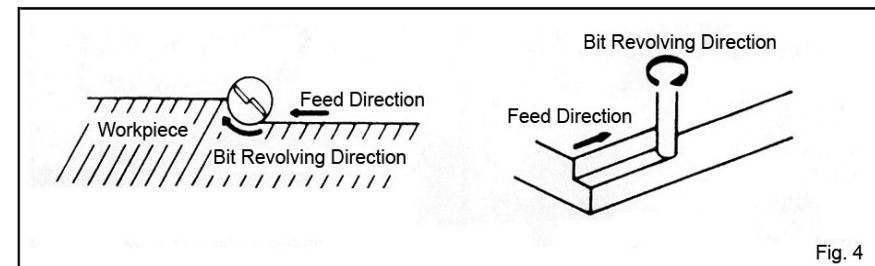
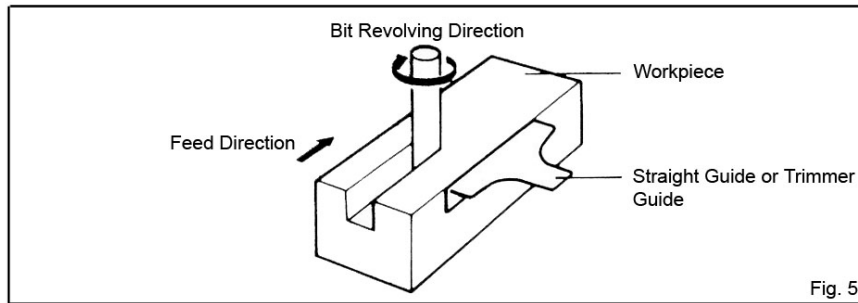

Fig. 4

NOTE:

- Moving the tool forward too fast may cause a poor quality of cut, or damage to the bit or motor. Moving the tool forward too slowly may burn and mar the cut. The proper feed rate will depend on the bit size, the kind of workpiece and depth of cut. Before beginning the cut on the actual workpiece, it is advisable to make a sample cut on a piece of scrap lumber. This will show exactly how the cut will look as well as enable you to check dimensions.
- When using the straight guide or trimmer guide, be sure to install it on the right side in the feed direction. This will help to keep it flush with side of the workpiece. (Fig. 5)



Straight Guide

The straight guide is effectively used for straight cuts when chamfering or grooving. (Fig. 6)

Attach the guide plate to the straight guide with the bolt, the wave washer, the flat washer and the wing nut. (Fig. 7)

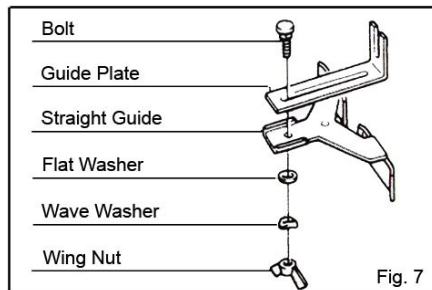
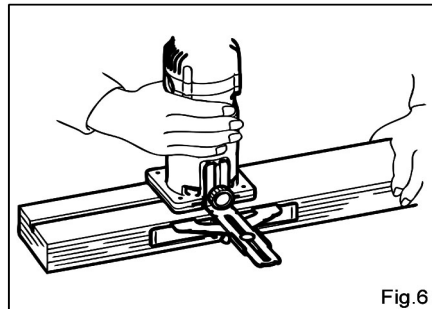

Remove the chip deflector. Attach the straight guide with the clamp screw (A).

Loosen the wing nut on the straight guide and adjust the distance between the bit and the straight guide. At the desired distance, tighten the wing nut securely. (Fig. 8)

When cutting, move the tool with the straight guide flush with the side of the workpiece.

If the distance (A) between the side of the workpiece and the cutting position is too wide for the straight guide, or if the side of the workpiece is not straight, the straight guide cannot be used. In this case, firmly clamp a straight board to the workpiece and use it as a guide against the trimmer base. Feed the tool in the direction of the arrow. (Fig. 9)

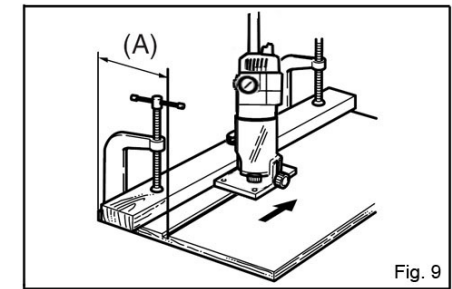
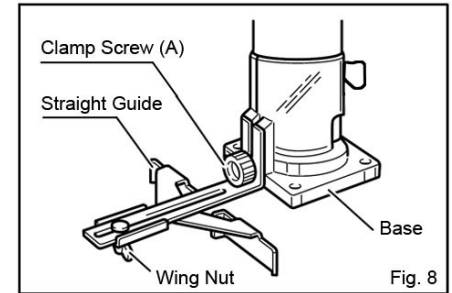

Circular Cutting

Circular cutting may be accomplished if you assemble the straight guide and guide plate as shown in (Fig. 10&11).

Minimum and maximum radius of circles to be cut (distance between the center of circle and the center of bit) are as follows:

Minimum radius: 70 mm (2-3/4");

Maximum radius: 221 mm (8-11/16").

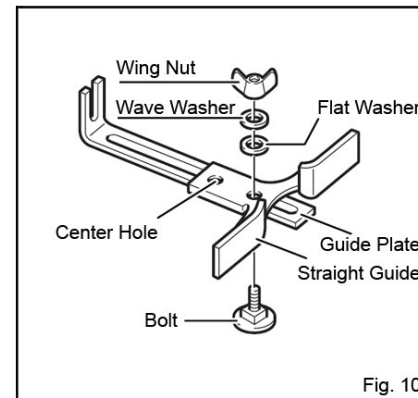

For cutting circles between 70 mm (2-3/4") and 121 mm (4-3/4") in radius.

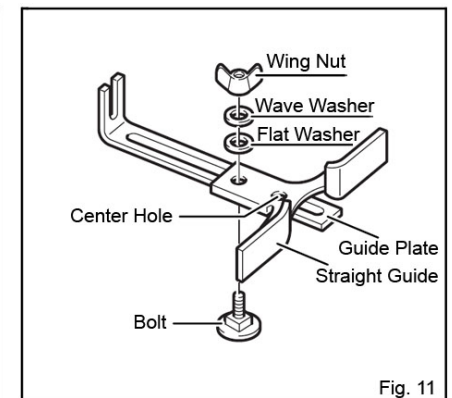

For cutting circles between 121 mm (4-3/4") and 221 mm (8-11/16") in radius.

NOTE:

Circles between 172 mm (2-3/4") and 186 mm (7-5/16") in radius cannot be cut by this straight guide.

Align the center hole in the straight guide with the center of the circle to be cut. Drive a nail less than 6 mm (1/4") in diameter into the center hole to secure the straight guide. Pivot the tool around the nail in clockwise direction. (Fig. 12)

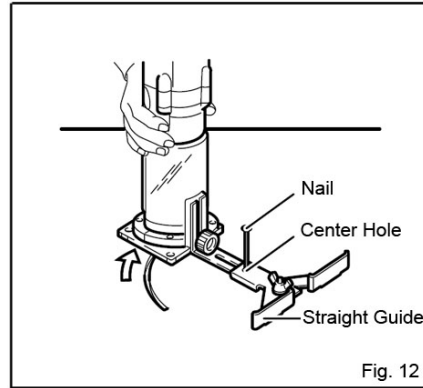

Trimmer Guide

Trimming, curved cuts in veneers for furniture and the like can be done easily with the trimmer guide. The guide roller rides the curve and assures a fine cut. (Fig. 13)

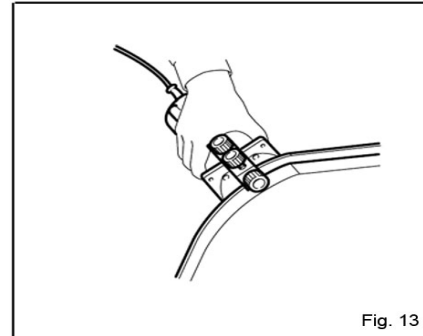

Install the trimmer guide on the tool base with clamp screw (A). Loosen clamp screw (B) and adjust the distance between the bit and the trimmer guide by turning the fine adjusting screw (1 mm or about 3/64" per turn). At the desired distance, tighten the clamp screw (B) to secure the trimmer guide in place. (Fig. 14)

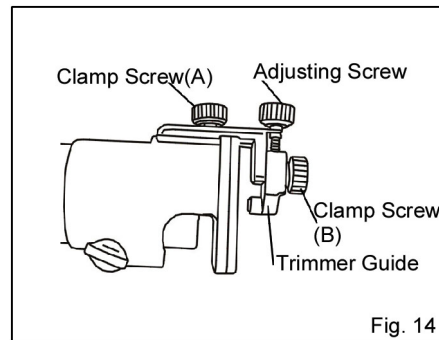

When cutting, move the tool with the guide roller riding the side of the workpiece. (Fig. 15)

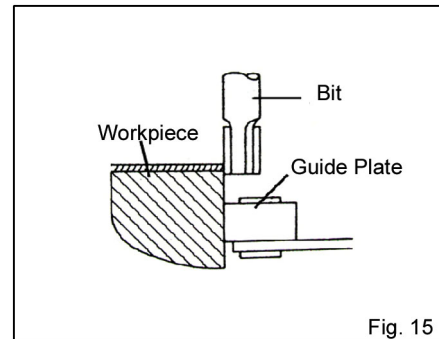

Templet Guide

The templet guide provides a sleeve through which the bit passes, allowing use of the trimmer with template patterns. (Fig. 16)

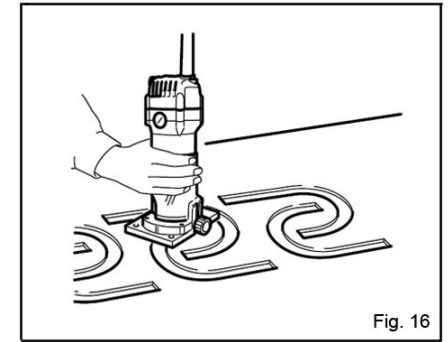

To install the templet guide, loosen the screws and remove the base protector. Place the templet guide on the base and then place the base protector on them. Then secure the base protector by tightening the screws. (Fig. 17)

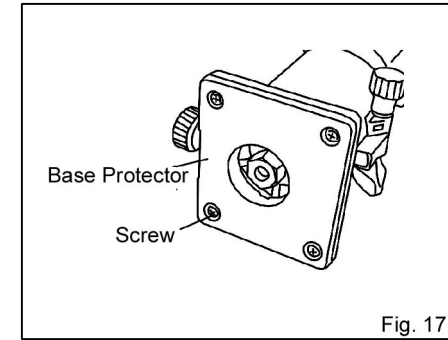

Secure the templet to the workpiece. Place the tool on the templet and move the tool with the templet guide sliding along the side of the templet. (Fig. 18)

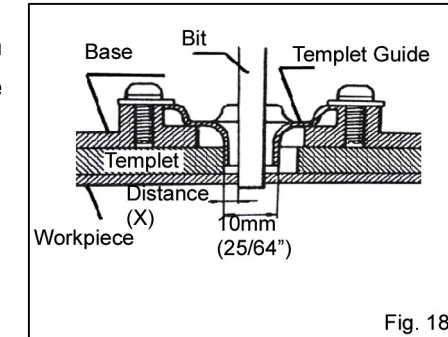

NOTE:

The workpiece will be cut a slightly different size from the templet. Allow for the distance (X) between the router bit and the outside of the templet guide. The distance (X) can be calculated by using the following equation:

$$\text{Distance (X)} = (\text{outside diameter of the templet guide} - \text{router bit diameter}) / 2$$

MAINTENANCE

CAUTION:

Always be sure that the tool is switched off and unplugged before attempting to perform inspection or maintenance.

Replacement of Carbon Brushes

Remove and check the carbon brushes regularly. Replace carbon brushes when they are worn down to the limit mark (Fig. 19). Keep the carbon brushes clean and free to slip in the holders. Both carbon brushes should be replaced at the same time. Use only identical carbon brushes.

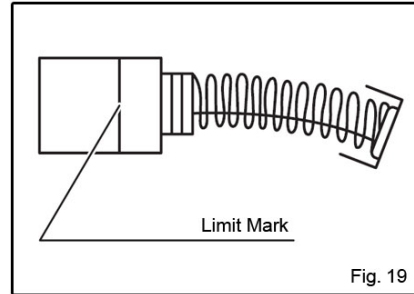

Use a screwdriver to remove the brush holder caps. Take out the worn carbon brushes, insert the new ones and secure the brush holder caps. (Fig. 20)

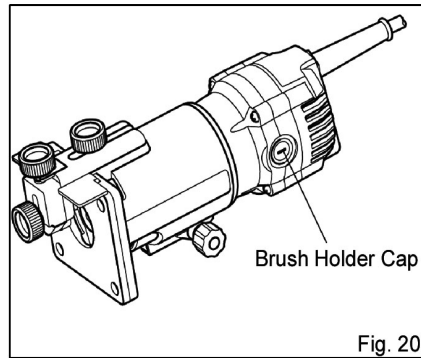

※ Damaged cord must be replaced by a special cord purchased from authorized service center.

※ To maintain product SAFETY and RELIABILITY, repairs, maintenance or adjustment should be carried out by authorized service center.

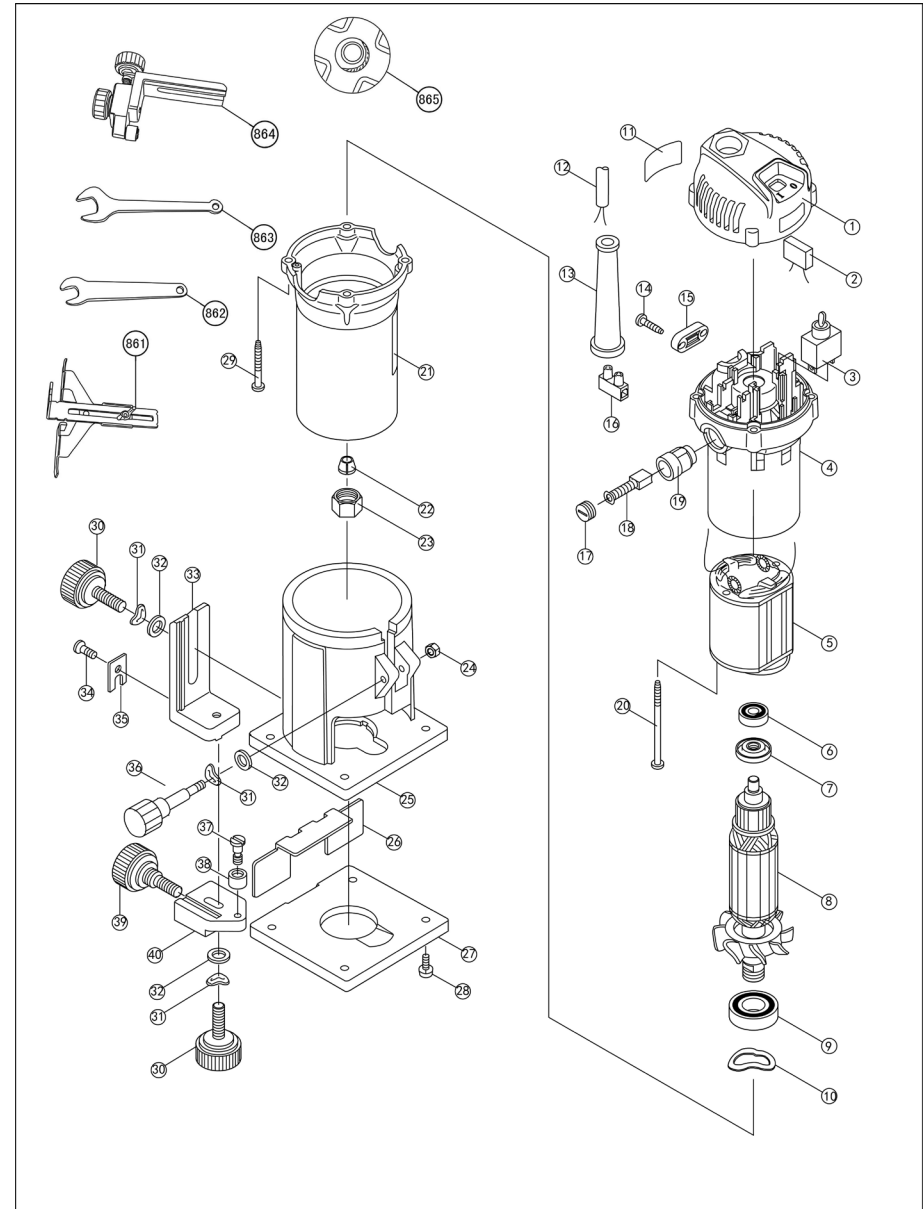

EXPLANATION OF GENERAL VIEW

1	Rear Cover	24	Hex Nut
2	Capacitor	25	Base
3	Switch	26	Chip Deflector
4	Gear Housing Cover	27	Base Protector
5	Stator Assembly	28	Pan Head Screw (with Flat Washer)
6	Ball Bearing	29	Pan Head Tapping Screw
7	Insulation Washer	30	Screw
8	Armature Assembly	31	Wave Washer
9	Ball Bearing	32	Flat Washer
10	Wave Washer	33	Guide Holder
11	Nameplate	34	Cross Recessed Countersunk Head Screw
12	Cord	35	Hook
13	Cord Guard	36	Screw
14	Pan Head Tapping Screw	37	Slotted Cheese Shoulder Screw
15	Strain Relief	38	Guide Roller
16	Terminal Block	39	Screw
17	Brush Holder Cap	40	Trimmer Guide
18	Carbon Brush	861	Straight Guide
19	Carbon Brush Holder	862	Wrench
20	Pan Head Tapping Screw	863	Wrench
21	Motor Housing	864	Trimmer Guide
22	Collect Cone	865	Templet Guide
23	Collect Nut		