

Model: SWRENC003

# CORDLESS BRUSHLESS IMPACT WRENCH

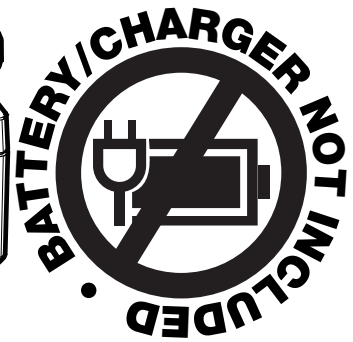

## OPERATING INSTRUCTIONS / USER MANUAL

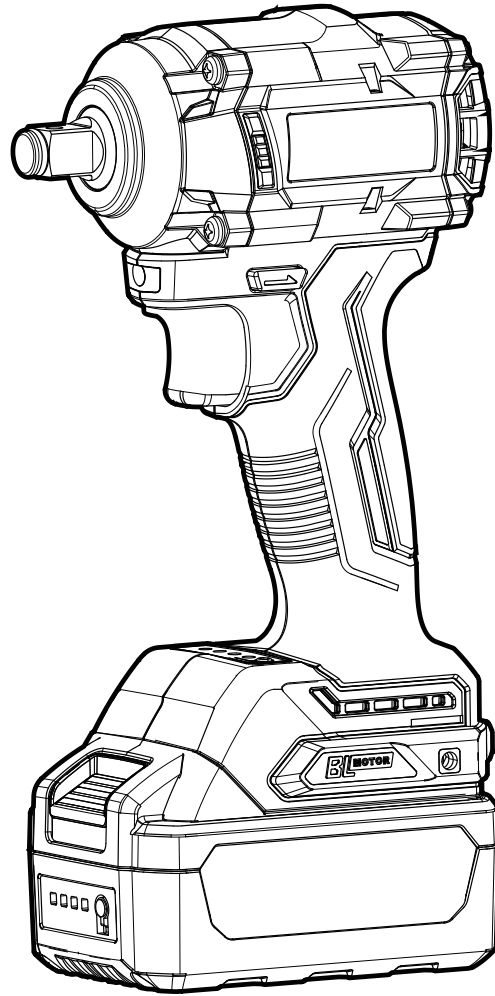

**Please read this manual carefully before use.  
Retain it for future reference. Failure to follow safety  
instructions may result in injury or product damage.**

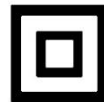

E&OE Please Note that details and specifications contained herein, are correct at the time of publishing. Adendorff reserve the right to change specifications at any time without prior notification.

vs1

# TABLE OF CONTENTS

Introduction	2
Technical Details & Specifications	3
Packaging Contents	3
Safety Warnings	4
PPE Requirements	5
Operating Environment Requirements	6
Further Safety Requirements	6
Battery Safety Warnings	7
Operating the Battery Cartridge	8
Notes for Operation	10
Switch Action	10
Installing or Removing the Tools	11
Tightening or Removing Bolt/Nut	12
Maintenance & Service Intervals	14
Storage Instructions	14
Troubleshooting	14
Disposal Guidelines	16
Parts List & Exploded Diagram	17
Customer Support - Repairs & Warranty	19
Service & Repair Contact Instructions	20

## WELCOME TO THE ADENDORFF FAMILY!

We are delighted to have you with us. To ensure you get the best performance from your new product, we kindly advise you to read the instruction manual thoroughly before installation and use. This will help you maximize its potential and ensure a smooth and safe experience.

Thank you for choosing our product. We appreciate your trust and support, and we are confident that it will serve you well. Should you have any questions or require further assistance, please feel free to reach out to us.

**IMPORTANT:** Please store and save this manual in a safe, dry place for future reference. It contains essential safety, maintenance, and troubleshooting information that may be needed during the product's lifetime.

## TECHNICAL DETAILS & SPECIFICATIONS

SPECIFICATION	VALUE	
<b>Model</b>	SWRENC003	
	DCPB358	
<b>Power Voltage</b>	20V	
<b>Square Drive</b>	12.7	
<b>Bolt Size</b>	M12 - M18mm	
<b>No-load Speed</b>	LOW	0 - 2000/min
	HIGH	0 - 2500/min
<b>Rated Impact Frequency</b>	LOW	0 - 2700/min
	HIGH	0 - 3100/min
<b>Torque</b>	L Gear / Power Saving Mode	300 N•m
	H Gear / Reverse Rotation Auto-Stop	358 N•m
<b>Net Weight of The Machine (Without Battery)</b>	1.1kg	

Inspect before each use. Do not use if there are broken, bent, cracked or damaged parts. Any product that appears damaged in any way, or operates abnormally shall be removed from service immediately. If the product has been subjected to a shock load (a load dropped suddenly, unexpectedly upon it), immediately discontinue use until it has been inspected by Adendorff Machinery Mart authorized service center. It is recommended that an annual inspection be done by qualified personnel. Labels and Operator's Manuals are available from manufacturer.

This cordless brushless impact wrench is designed for tightening and loosening threaded fasteners such as nuts and bolts. It delivers high torque output, making it suitable for demanding applications in automotive, construction, and general maintenance work. The brushless motor ensures improved efficiency, longer tool life, and reduced maintenance. This tool is intended for DIY use in environments where a portable, high-performance fastening solution is required. It should only be used for its intended purpose and in accordance with the safety instructions provided in this manual.

## PACKAGING CONTENTS

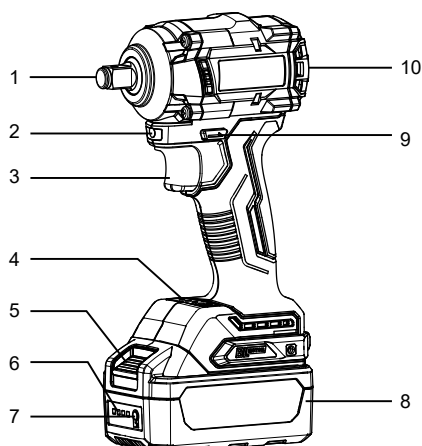

1. Anvil
2. Work Light
3. Switch Trigger
4. Torque Setting Panel
5. Battery Pack Button
6. Power Indicator Light
7. Battery Indicator Button
8. Battery Pack
9. Reversing Switch Lever
10. Rear Cover Of Motor Housing

# SAFETY WARNINGS

## WARNING!

**Read and save all safety warnings and instructions carefully. Failure to follow these warnings may result in electric shock, fire, or serious injury. Keep all warnings and instructions for future reference.**

### ELECTRICAL SAFETY

- **Ensure electrical tool plugs match the outlet.** Never modify the plug in any way or use adapter plugs with earthed (grounded) power tools. Properly matched, unmodified plugs and outlets reduce the risk of electric shock.
- **Avoid contact with earthed or grounded surfaces** such as pipes, radiators, ranges, and refrigerators. Contact with these surfaces increases the risk of electric shock.
- **Keep electrical tools away from rain or wet conditions.** Water entering a power tool significantly raises the risk of electric shock.
- **If using a electrical tool in a damp location is unavoidable,** ensure the power supply is protected by a **Ground Fault Circuit Interrupter (GFCI)**. A GFCI reduces the risk of electric shock in such conditions.

### PERSONAL SAFETY

- **Stay alert and focused.** Always pay attention to what you are doing and use common sense when operating a power tool. Avoid using power tools if tired or under the influence of drugs, alcohol, or medication. A moment of inattention can result in serious personal injury.
- **Prevent unintentional starting.** Ensure the switch is in the OFF position before connecting the tool to a power source, attaching a battery pack, picking up, or carrying the tool. Carrying tools with your finger on the switch or connecting power while the tool is on increases the risk of accidental activation.
- **Remove all adjusting keys or wrenches before turning on the tool.** Leaving these attached to rotating parts can cause serious personal injury.
- **Maintain proper footing and balance.** Avoid overreaching, and always keep a stable stance to retain control of the tool in unexpected situations.
- **Use dust extraction and collection systems if available.** Properly connecting and using these systems helps reduce dust-related hazards.

### POWER TOOL USE AND CARE

- **Use the correct tool for the job.** Do not force the power tool to perform tasks it is not designed for. The appropriate power tool will complete the task more efficiently and safely when used as intended.
- **Ensure proper operation of the switch.** Do not use the power tool if the switch does not properly turn it on and off. A tool that cannot be controlled via the switch is hazardous and should be repaired before use.
- **Disconnect the power source before adjustments.** Always unplug the Tool or remove the battery pack before adjusting, changing accessories, or storing the tool. This precaution prevents accidental activation.
- **Store tools securely and out of reach of children.** Keep idle power tools in a safe location, away from children and individuals unfamiliar with their operation. Tools in the hands of untrained users can be dangerous.

- **Maintain tools.** Regularly inspect power tools for misalignment, binding of moving parts, breakage, or any condition that may affect their performance. Damaged tools should be repaired before use, as poorly maintained tools are a common cause of accidents.
- **Keep cutting tools sharp and clean.** Properly maintained and sharp cutting edges reduce the likelihood of binding and make the tool easier to control.
- **Follow the tool's instructions and intended use.** Use the power tool, accessories, and bits according to the provided instructions and the conditions of the task. Using tools for unintended applications can lead to hazardous situations.

### **BATTERY TOOL USE AND CARE**

- **Recharge only with the charger specified by the manufacturer.** Using a charger designed for a different battery pack may pose a risk of fire or damage to the battery.
- **Use designated battery packs.** Operate tools only with the specific battery packs recommended by the manufacturer. Using other battery packs may result in injury or fire.
- **Store battery packs safely.** When not in use, keep the battery pack away from metal objects such as paper clips, coins, keys, nails, or screws. These items can create a connection between terminals, potentially causing burns or a fire.
- **Handle leaking batteries with care.** Under abusive conditions, liquid may leak from the battery:
- **Avoid contact with the liquid.** If accidental contact occurs, flush the area with water. If the liquid enters the eyes, rinse thoroughly with clean water for at least 10 minutes and seek medical attention. Battery liquid may cause irritation or burns.

### **SERVICE**

- **Use qualified service professionals.** Always have tools serviced by a qualified repair technician at Adendorff Machinery Mart [www.adendorff.co.za](http://www.adendorff.co.za), ensuring that only identical replacement parts are used. This guarantees the safety and performance of the tool.
- **Adhere to maintenance guidelines.** Follow the manufacturer's instructions for lubrication and accessory changes to maintain the tool's functionality and longevity.
- **Maintain cleanliness.** Keep handles and external surfaces dry, clean, and free from oil and grease. A clean tool provides better grip and reduces the risk of slipping during use.

## **PPE REQUIREMENTS**

- **Use appropriate personal protective equipment.** Always wear eye protection, and use additional protective equipment such as a dust mask, non-skid safety shoes, a hard hat, or hearing protection, depending on the conditions. These measures reduce the risk of injury.
- **Dress appropriately.** Avoid wearing loose clothing or jewellery, and ensure long hair is tied back. Keep hair, clothing, and gloves away from moving parts to prevent entanglement.

## OPERATING ENVIRONMENT REQUIREMENTS

- **Keep the work area clean and well-lit.** Cluttered or poorly lit spaces increase the risk of accidents.
- **Avoid operating power tools in explosive atmospheres.** Do not use tools in environments with flammable liquids, gases, or dust, as power tools generate sparks that could ignite these substances.
- **Keep children and bystanders at a safe distance** while operating a power tool. Distractions can lead to a loss of control, increasing the risk of injury.

## FURTHER SAFETY REQUIREMENTS

1. **To be safe, disabled, retarded, untrained people or people disable to operate independently, including young children, are discouraged to operate the tool without supervision. Young children should be supervised to ensure that they do not play with the tool.**
2. **Check the tool and battery carefully before putting it into use. Stop operation immediately when malfunctions be found and send the tool to be repaired by qualified serviceman. Do not open the tool yourself.**
3. **Use only original type rechargeable Li-Ion battery for this tool and recharge only with the type charger supplied with the tool. Use of other type of battery or charger, e.g. imitated, modified or with other brand, may result in a risk of battery burst causing personal injury and property damage.**
4. **Be sure that the battery is installed correctly and tightly before operating the tool.**
5. **Always wear protective devices to avoid personal injury.**
6. **Hold tool by insulated gripping surfaces when performing an operation on wall and floor where the cutting tool may contact hidden wiring. Contact with a “live” wire will also make exposed metal parts of the tool “live” and shock the operator.**
7. **Use appropriate detectors to determine if utility lines, such as electric lines, gas lines and water lines, are hidden in the work area before screwing or drilling on the wall, floor or ceiling.**
8. **Keep working area well ventilated. Non-specified or damaged battery may produce poisonous gases causing personal injury.**
9. **Always be sure to have a firm footing and hold the tool firmly.**
10. **Be sure no one is below when using the tool in high locations.**
11. **Keep hands away from rotating parts.**
12. **Switch off the tool immediately once the drill bit is blocked as the motor or the battery maybe damaged because of overloaded. Free the drill bit by reversing the rotation of the drill bit which can be controlled by the switch.**
13. **Do not leave the tool running. Operate the tool only when hand-held.**
14. **Do not touch the drill bit or the workpiece immediately after operation; they may be extremely hot and could burn your skin.**
15. **Do not overload the tool; it may result in a risk of overheating.**
16. **Some material contains chemicals which may be toxic. Take caution to prevent working dust inhalation and skin contact. Follow material supplier safety data.**
17. **Always disconnect the battery from the tool before making any work on the tool.**
18. **Before performing any kind of work on the tool (e.g. maintenance, bit change, etc.) as well as when transporting and storing it, always set the reversing switch lever to the center position. Unintentional activation of the On/Off switch may result in personal injury.**

19. Only use soft and dry cloth to wipe the body of the tool. Do not clean the tool with wet cloth, thinner, gasoline or other volatile solvents.
20. The damaged tools, accessories and waste packaging should be sorted for environmentally friendly recycling and in accordance with local laws.

## **BATTERY SAFETY WARNINGS**

- Do not dismantle, open or shred secondary cells or batteries.
- Keep batteries out of the reach of children. Battery usage by children should be supervised. Especially keep small batteries out of reach of small children.
- Do not expose cells or batteries to heat or fire. Avoid storage in direct sunlight.
- Do not short-circuit a cell or a battery. Do not store cells or batteries haphazardly in a box or drawer where they may short-circuit each other or be shortcircuited by other metal objects.
- Do not subject cells or batteries to mechanical shock.
- In the event of a cell leaking, do not allow the liquid to come in contact with the skin or eyes. If contact has been made, wash the affected area with copious amounts of water and seek medical advice.
- Do not use any charger other than that specifically provided for use with the equipment.
- Do not use any cell or battery which is not designed for use with the equipment.
- Do not mix cells of different manufacture, capacity, size or type within a device.
- Always purchase the battery recommended by the device manufacturer for the equipment.
- Keep cells and batteries clean and dry. Wipe the cell or battery terminals with a clean dry cloth if they become dirty.
- Secondary cells and batteries need to be charged before use. Always use the correct charger and refer to the manufacturer's instructions or equipment manual for proper charging instructions.
- Do not leave a battery on prolonged charge when not in use.
- After extended periods of storage, it may be necessary to charge and discharge the cells or batteries several times to obtain maximum performance.
- Retain the original product literature for future reference.
- Use the cell or battery only in the application for which it was intended.
- When possible, remove the battery from the equipment when not in use.
- Keep the cell or battery away from microwaves and high pressure.
- Dispose of properly.

# OPERATING THE BATTERY CARTRIDGE

## BATTERY CHARGING

- The battery pack can only be charged by the charger that comes with the machine. Never use other charger.
- In a high temperature environment or after a long time of use, the machine may become hot. Please do not immediately charge the battery until it cools down. Otherwise, the service life of the battery pack will be shortened or the battery pack will not be able to be charged due to overheating.
- A battery that is new or has not been used for a long period of time does not develop its full capacity until after approximately 3-4 charging/discharging cycles.
- A significantly reduced working period after charging indicates a used up battery that must be replaced.

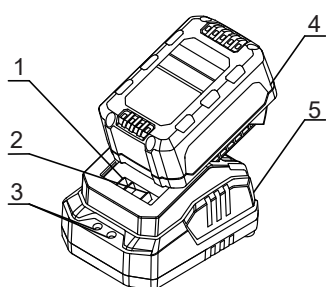

1. Negative Pole
2. Positive Pole
3. Indicator Light
4. Battery Pack
5. Charger

## INSTALLING OR REMOVING BATTERY PACK

### CAUTION:

- When installing or removing the battery pack, please insure that the switch is off to avoid danger. The battery pack is only partially charged when delivered. In order to ensure the maximum power of the battery, the battery pack must be fully charged in the charger before the first use.

### 1. Installing the battery pack

As below, when inserting the battery pack, pay attention to insert the battery pack into the housing correctly. Be sure to insert the battery pack until you hear the “click” sound, which means that the battery pack has been firmly installed on the tool. Otherwise, the battery pack will accidentally fall off the housing, causing injuries to the operator or others. Avoid inserting the battery pack with excessive force or tapping it in with the help of other objects.

### CAUTION:

Only the specified type of battery pack can be used. The use of battery packs of other brands carries the risk of injury, personal injury and property damage due to battery pack explosion.

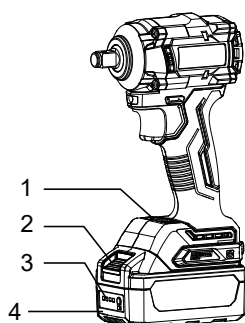

1. Torque Setting Panel
2. Battery Pack Button
3. Power Indicator Panel
4. Battery Pack

## 2. Removing the battery pack

The battery pack is equipped under the machine handle, press the battery pack button down in the direction of arrow, and then pull out the battery pack in the direction of arrow as shown in the figure.

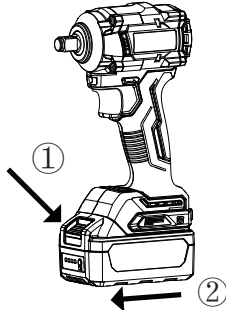

### CAUTION:

#### **DON'T PULL OUT THE BATTERY FORCIBLY!**

1. Press the battery pack button down in the direction of arrow
2. Pull out the battery pack in the direction of arrow

## BATTERY INDICATOR LIGHT

When the battery pack button is pressed, the light will display the power of the battery, indicated by the status of the four red LED lights (hereinafter referred to as red light).

STATUS OF RED LED LIGHTS	APPROX. BATTERY POWER LEFT
4 red lights lit	75%~100%
3 red lights lit	50%~75%
2 red lights lit	25%~75%
1 red lights lit	10%~25%
1 light flashing	Battery low

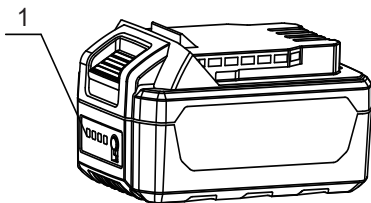

1. Battery Indicator Light

## CONTINUOUS USE

If the tool is operated continuously until the battery has discharged, allow the tool to rest for 15 minutes before proceeding with a fresh battery.

## OVER-DISCHARGE PROTECTION

The tool is equipped with a protective circuit to protect the battery against over-discharging. When the battery is near to be empty, the protective circuit actuates to switch off the tool.

## DISPOSAL OF BATTERY

To protect natural resources, please recycle or dispose of batteries properly. The battery contains lithium. Consult your local authority for information on recycling and/or disposal. Remove the battery after it has run out of power and wrap the pole port with strong tape to avoid short circuit and leakage. Any attempt to open or remove any component is strictly prohibited.

## NOTES FOR OPERATION

1. Always keep workpiece secured or well clamped to avoid looseness.
2. Any move of workpiece will affect the actual cutting or polishing quality.
3. Do not use damaged sandpaper, which will damage the baseplate of the machine. Our quality assurance does not include the wear of the baseplate.
4. Use sanding sheet of coarse sand for rough surfaces; medium grain size for smooth surfaces; fine sand for final sanding. Sand on scraps firstly for test if necessary
5. Intensifying pressure will decrease the operating capacity of the machine and lead to an overload of the motor. Replacing accessories in due course can keep the machine working efficiently.

## SWITCH ACTION

- To start the tool, simply pull switch trigger. Tool speed is increased by increasing pressure on the switch trigger and further pressure results in an increase in speed. Release the switch trigger to switch off the tool.

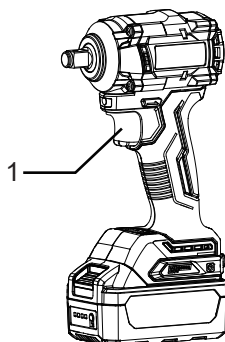

### CAUTION:

Before inserting the battery cartridge into the tool, always check to see that the switch trigger actuates properly and returns to the "OFF" position when released. Do not operate the machine at a low speed for too long, or the inside machine may be overheated.

### 1.Switch Button

## REVERSING SWITCH ACTION

Depress the reversing switch lever from side B to side A for clockwise rotation for drilling and driving in screws (viewed from the rear of the tool). Depress the reversing switch lever from side A to side B for counterclockwise rotation for loosening or unscrewing screws (viewed from the rear of the tool).

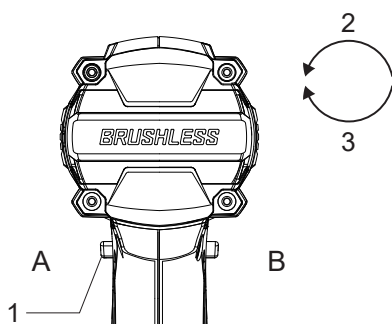

### 1.Switch Trigger

### 2.Anticlockwise

### 3.Clockwise

**CAUTION:** Always check the direction of rotation before operation. Operate the reversing switch only after the tool comes to a complete stop. Changing the direction of rotation before the tool stops may damage the tool. When not operating the tool, always set the reversing switch lever to the center position(Lock the switch). Never force to push the switch trigger while the reversing switch lever is set at the center position.

## INSTALLING OR REMOVING TOOLS

Tools referred to here include sockets, etc., and are not equivalent to power tools or machines.

**Caution:** Always set the reversing switch lever to the center position before operation and pull out the battery pack. Never force to push the switch trigger.

### INSTALLING THE TOOL

To install the socket, insert it into the end the wrench. Check if the socket is installed on the tool firmly. The socket is inserted to the innermost end of the anvil, insert the pin, with a rubber ring attached to ensure that the socket does not fall off freely, and it must be checked that the insertion tool is firmly attached to the anvil of the machine.

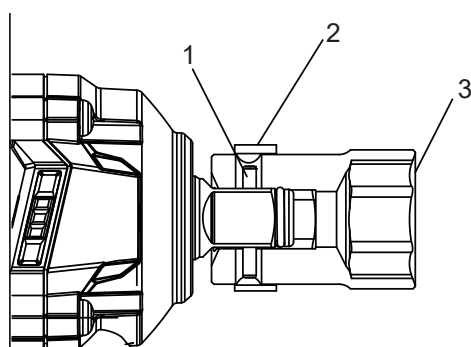

- 1.Pin
- 2.Rubber Ring
- 3.Socket

### REMOVING THE TOOL

Uncover the Socket Rubber Ring, take out the pin and pull the socket along the direction of the arrow.

**Caution:** If the pin is found to be worn or broken, please replace it in time.

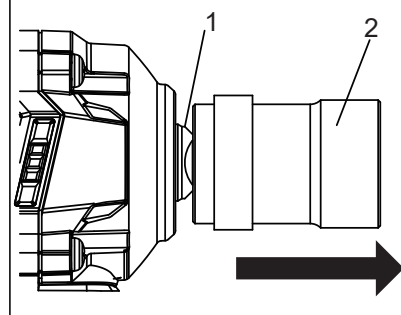

- 1.Anvil
- 2.Socket

# TIGHTENING OR REMOVING BOLT/NUT

## 1.TIGHTENING BOLT/NUT

Place the socket in the bolt head and apply pressure to the tool. Start the tool slowly and then increase the speed gradually. Release the switch trigger when the bolt fixed tightly.

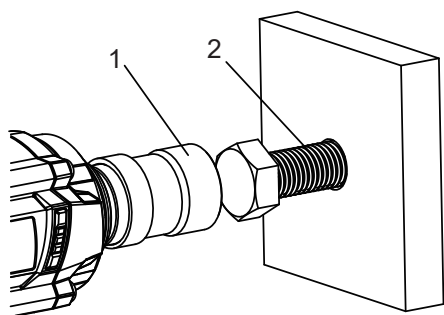

**CAUTION:**

Point the bolt to threaded hole as vertically as possible.

- 1. Bolt
- 2. Socket

## 2.REMOVING BOLT/NUT

Place the socket in the bolt head and start the tool to its full speed. After bolt was removed completely, release the switch trigger slowly.

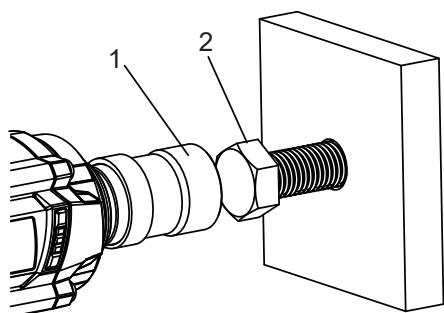

**CAUTION:**

Set reversing switch lever for counterclockwise rotation when removing the bolt.

- 1. Bolt
- 2. Socket

## TORQUE SETTING

The machine is provided with 4 gears of torque adjustment. Touch and press the switch button on the torque control panel to realize the switch of the Power Saving, Reverse Rotation Auto-Stop, L, and H gears, so as to adapt to different site requirement

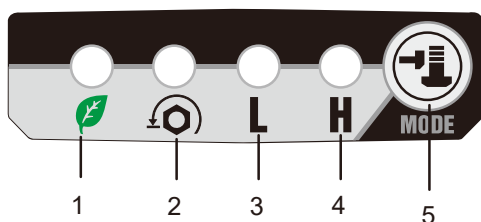

- 1.Power Saving Mode
- 2.Reverse Rotation Auto-Stop
- 3.Low Gear
- 4.High Gear
- 5.Toggle Button

**POWER SAVING MODE:** On the basis of reverse autostop, the function of forward rotation self-stop is added. When switching to this gear and the reversing lever is placed in forward rotation, tighten the bolt.

Once the bolt is tightened, the machine will stop working immediately, even if the switch has not been loosened. This function can effectively prevent the bolt from continuous impact when tightening the bolt.

**REVERSE ROTATION AUTO-STOP:** It is a unique reverse auto-stop gear. When switching to this gear to loosen bolts with the reversing lever is placed in reverse. Once the bolt is loosened, the machine will stop working immediately, even if the switch has not been loosened. This function can effectively prevent accidental loosening of bolts when loosening; Forward rotation and H gear are the same.

**L GEAR:** Press and hold the switch trigger, and the machine continues to work at a lower speed, the maximum torque can reach 300N•m.

**H GEAR:** Press the switch trigger and run the tool at the speed of maximum, the maximum torque can reach 358N•m.

**CAUTION:** Please use 4 different gears reasonably according to the usage requirements in work occasions.

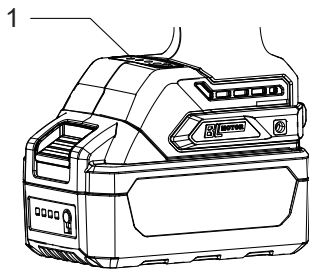

1.Torque Setting Panel

### WORK LIGHT

The white LED work light will be lit when pull the switch trigger, allows for illumination of the work area under unfavorable lighting conditions.

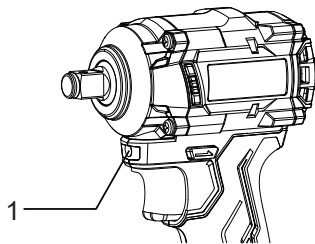

1.Work Light

## MAINTENANCE & SERVICE INTERVALS

- **Clean the air vents** The air inlet and air outlet of the tool should be cleaned regularly or at any time when it is blocked.
- **Dust Cover** Check the mounting screws. Should always check whether mounting screw fastening safely. If found loose screws, shall be immediately to tighten, so as to avoid an accident.
- **Avoid harmful substances:** Do not use petrol, diesel, benzene, thinner, alcohol, or similar substances for cleaning. These chemicals can cause discoloration, deformation, or cracks in the tool's materials. Wipe clean as needed. Use mild upholstery cleaner (not caustic) to clean as needed.

### NOTE:

- **Authorized repairs only:** To ensure product safety and reliability, all repairs, maintenance, or adjustments should be performed exclusively by Adendorff Machinery Mart Authorized Service Centers.
- **Use genuine parts:** Always use Adendorff Machinery Mart-approved replacement parts to maintain the tool's performance and warranty coverage.

## STORAGE INSTRUCTIONS

- **Keep the tool stored in a dry, level area,** away from dampness, moisture, and rainfall.
- **Allow the tool to cool down completely before storing.**
- **Ensure the tool is clean and dry before storage.**
- **Store the tool in a position where it cannot be accidentally stepped on or moved, especially to reach higher items.**

### DO NOT:

- **Do not store the tool near an ignition source, such as a wood stove, gas or electric heater, or any appliance with a pilot light.**
- **Do not stack heavy or other items on top of the tool during storage.**

### IMPORTANT:

- **Store the tool out of reach of children or individuals unfamiliar with its operation.**
- **Avoid direct sunlight or extreme temperatures. Store the tool indoors or in a safe, frost-free area**

## TROUBLESHOOTING

When troubleshooting electric and battery-operated tools, start by checking the power source ensure the battery is charged or the tool is properly plugged into a functional outlet. Inspect the power switch, fuses, and any reset buttons for signs of malfunction.

Look for visible damage to cords, connectors, or terminals, as these can interrupt the power flow.

If the tool still doesn't operate, remove any obstructions, clean the contacts, and verify that all safety features or interlocks are properly engaged.

FAULT	CAUSE	REMEDY
<b>The machine does not work, The battery pack is fully charged and contact.</b>	<ol style="list-style-type: none"> <li>1. Poor contact between battery pack and the machine.</li> <li>2. Machine parts are damaged.</li> </ol>	<ol style="list-style-type: none"> <li>1. Reinstall the battery pack.</li> <li>2. Send the machine back to the original factory or maintenance point for repair.</li> </ol>
<b>The machine broke down suddenly while it was working</b>	<ol style="list-style-type: none"> <li>1. The battery pack runs out of power</li> <li>2. High temperature or overload protection</li> <li>3. Machine parts are damaged.</li> </ol>	<ol style="list-style-type: none"> <li>1. Recharge the battery pack or replace the fully charged battery pack.</li> <li>2. Leave the machine and battery pack to cool.</li> <li>3. Send the machine back to the original factory or maintenance point for repair.</li> </ol>
<b>The noise of the machine or the temperature is too high</b>	<ol style="list-style-type: none"> <li>1. The gear box is short of lubricating oil</li> <li>2. The machine absorbs dust or iron filings</li> <li>3. Machine parts are damaged.</li> </ol>	<ol style="list-style-type: none"> <li>1. Add special lubricating oil.</li> <li>2. Clean the machine.</li> <li>3. Send the machine back to the original factory or maintenance point for repair.</li> </ol>
<b>The socket comes off easily from the anvil</b>	<ol style="list-style-type: none"> <li>1. The socket is worn.</li> <li>2. The spiral retaining ring of the anvil is worn</li> </ol>	<ol style="list-style-type: none"> <li>1. Replace the socket.</li> <li>2. Send the machine back to the original factory or maintenance point for repair.</li> </ol>

This product can use a variety of external tools, users can change the tool according to the actual job requirements, the use of methods can refer to the following figure. The accessories mentioned in the figures or in the instructions are not included in the scope of supply.

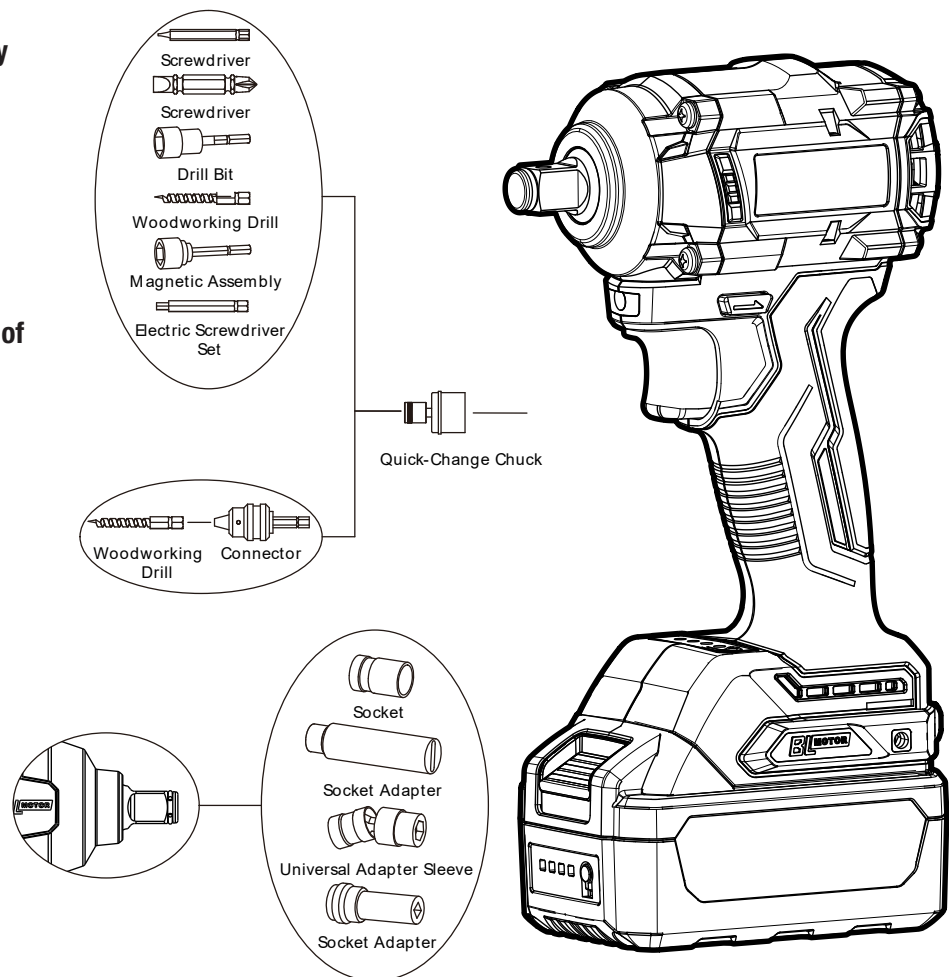

## **DISPOSAL GUIDELINES**

**When disposing of electric and battery-operated tools, always follow local regulations and environmental guidelines. Start by removing any batteries, as they require separate handling due to their hazardous materials—recycle them at designated battery recycling centers or collection points.**

**For the tool itself, do not throw it in regular trash; instead, take it to an authorized e-waste recycling facility or a community hazardous waste disposal event.**

**Always erase any personal data stored in smart tools and ensure components are safely handled to prevent environmental contamination or injury.**

## PARTS LIST & EXPLODED DIAGRAMS

DESCRIPTION	
1	Cross Recessed Pan Head Tapping Screw ST4×24 (With Spring Washer)
2	O Ring (14×2)
3	Anvil Assembly
6	Drive Spindle Washer (Iron)
8	Hammer Assembly
9	Planet Gear
10	Cylindrical Pin 4×9.7
11	Washer
12	Ring Gear
13	O Ring (7.5×2)
14	Bearing 6804-2RS
15	Rear Cover
17	Bearing 625DD(LFB)
19	Stator
20	Rear Cover
21	Rolling Bearing 608VV
22	LED Shade
23	Reversing Switch Lever
24	Switch
25	Torque Setting Panel
26	Control Panel
27	Terminal
28	Motor Housing Assembly
29	Rubber Pin
30	Battery Pack
31	Battery Charger
T1	Armature With Bearings
T2	Gear Housing Assembly Of Gearbox
T3	Mechanical Output Assembly

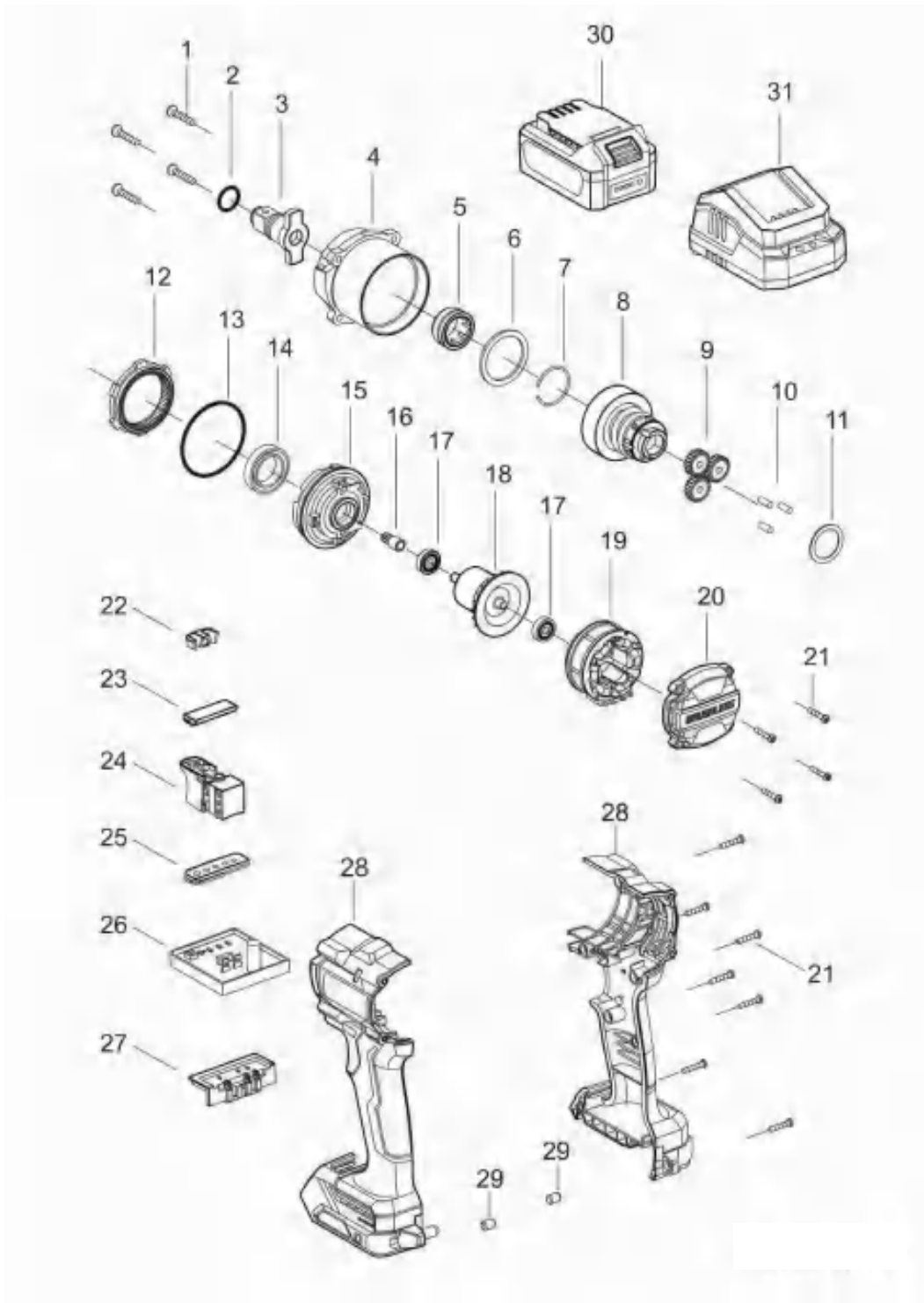

## CUSTOMER SUPPORT – REPAIRS & WARRANTY

**A “CARRY-IN” CONDITIONAL WARRANTY APPLIES ON ALL GOODS PURCHASED.**

### WARRANTY PERIOD

- This product is warranted for 12 months from the date of purchase by the first user.

### COVERAGE

- The warranty covers all material or production flaws, with exceptions:
  - Batteries and chargers
  - Parts subject to normal wear (e.g., bearings, brushes, cables, plugs)
  - Accessories (e.g., drill bits, saw blades)

### EXCLUSIONS

- The warranty does not cover damage or defects from:
  - Maltreatment, accidents, or alterations
  - Inappropriate or negligent use of the tool
  - Overloading, fluid permeation, excessive dust, or intentional damage
  - Non-compliance with manual instructions, inexperienced assembly, lightning, or incorrect voltage

### LIABILITY

- Adendorff Machinery Mart disclaims liability for bodily injury resulting from improper tool use.

### REPAIRS

- All Warranty repairs must be conducted by an authorized Adendorff Machinery Mart repair center. All stores have in-house service technicians.

### TRANSPORTATION COSTS

- Transportation costs for service are the customer’s responsibility unless otherwise agreed in writing.

### WARRANTY CLAIMS

- All Warranty claims do not extend or restart the warranty period.
- Claims may be rejected if purchase cannot be verified or if product maintenance is found to be lacking.
- A 3-month (Three Months) warranty applies to any repairs performed.
- Cross Border customers, **PLEASE NOTE** that our warranty only applies to items purchased and used within the Republic of South Africa. Any items exported which are found to be faulty must be returned to Adendorff Machinery Mart at your own cost.

### MAINTENANCE AND PROOF OF PURCHASE

- Maintain the product as instructed (e.g., clean ventilation slots, service carbon brushes regularly).
- Retain the purchase receipt as proof of purchase date.

# SERVICE & REPAIR CONTACT INSTRUCTIONS

## RETURN CONDITIONS

- Return the product intact, in clean condition, and in its original blow-molded case (if applicable), along with proof of purchase.

## 1. LOCATE YOUR NEAREST BRANCH

Visit our website at [www.adendorff.co.za](http://www.adendorff.co.za) and use the Store Locator to find the nearest branch to you.

## 2. PREPARE PRODUCT DETAILS

Before contacting or visiting a branch, please have the following information ready:

- Product name and model number
- Proof of purchase (invoice or receipt)
- A brief description of the issue or fault

## 3. CONTACT OR VISIT THE BRANCH

**Phone:** Call your nearest Adendorff Machinery Mart branch directly for repair intake or service queries.

**In Person:** Bring the product to the branch for assessment. Ensure it is clean and safely packed for transport.

## 4. WARRANTY REPAIRS

If your item is still under warranty, repairs will be handled according to the warranty terms. Ensure you bring the original receipt with the product.

## 5. OUT-OF-WARRANTY REPAIRS

For items no longer under warranty, a quotation will be provided for approval before any work begins.

**Note:** Repairs may take several business days depending on parts availability and workshop load. You will be contacted once your item is ready for collection.

**For full warranty details, visit [www.adendorff.co.za](http://www.adendorff.co.za). For assistance, contact the national call centre at 011 434 7000.**



SUPPLIED BY



[www.adendorff.co.za](http://www.adendorff.co.za)