

Model: GWINCH503

# MAC AFRIC 2200lbs/1000kg HAND WINCH

With Dacromet Anti-Corrosion Coated Finish/ Nylon Strap – 50mm \*7m

## ORIGINAL OPERATING INSTRUCTIONS



SUPPLIED BY  
**Adendorff**  
machinery mart  
[www.adendorff.co.za](http://www.adendorff.co.za)



Model: GWINCH503

# MAC AFRIC 2200lbs/1000kg HAND WINCH

With Dacromet Anti-Corrosion Coated Finish/Nylon Strap – 50mm \*7m

## Product Introduction

This hand-operated winch is designed for controlled pulling, tensioning, and positioning of loads in workshop, site, marine, agricultural, and general utility applications.

It uses a ratchet-driven gear system with selectable ratios to provide mechanical advantage during load movement.

### ⚠ IMPORTANT LIMITATION

This winch is **NOT** designed, rated, or approved for vehicle recovery or self-rescue applications. It must not be used for snatch recovery, towing vehicles, or dynamic loads.

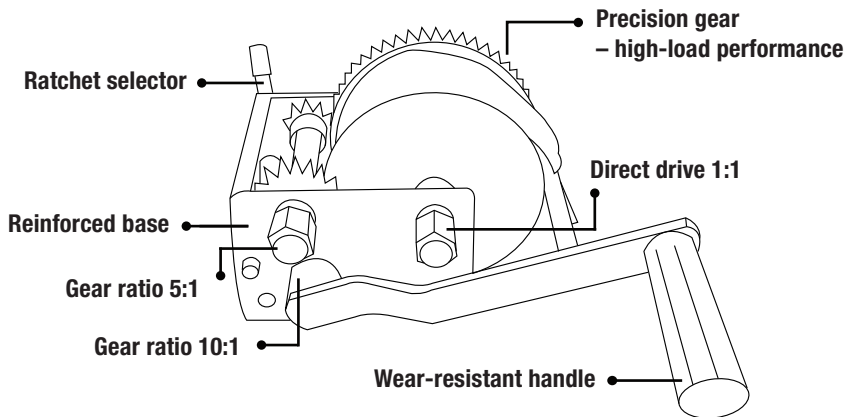

## Intended Use

This winch is intended for:

- Load pulling and dragging on flat or controlled surfaces
- Load positioning and alignment
- Trailer loading and securing
- Boat positioning on trailers or slipways
- Workshop and site-based material handling
- Agricultural and utility pulling tasks

× Not intended for:

- Vehicle self-recovery or rescue
- Lifting or hoisting loads vertically
- Supporting suspended loads
- Dynamic or shock loading

Model: GWINCH503

# MAC AFRIC 2200lbs/1000kg HAND WINCH

With Dacromet Anti-Corrosion Coated Finish/Nylon Strap – 50mm \*7m

## Key Features

- Dacromet anti-corrosion coating for extended service life
- Heavy-duty steel construction
- Dual-speed ratchet mechanism (1:1 / 5:1 / 10:1)
- 7 m nylon webbing strap (50 mm width)
- Forward and reverse ratchet control
- Manual crank operation

## Safety Warnings

### WARNING – RISK OF SERIOUS INJURY

1. Never exceed the rated load of 1000 kg.
2. This winch is designed for pulling only, not lifting.
3. Do not use for vehicle rescue or recovery.
4. Keep hands, clothing, and loose objects clear of gears, ratchet, and webbing.
5. Always wear gloves when operating the winch.
6. Do not modify, disassemble, or repair the winch without authorisation.
7. Inspect before each use. Remove from service if damaged or worn.

## PPE Requirements

- Protective gloves (mandatory)
- Safety footwear
- Eye protection when working near tensioned loads

## Operating Environment Requirements

- Install on a firm, flat, and rigid surface
- Suitable for indoor or outdoor use
- Protect from prolonged exposure to moisture when not in use
- Do not operate in unstable or uneven mounting conditions

## Installation & Mounting

Model: GWINCH503

# MAC AFRIC 2200lbs/1000kg HAND WINCH

With Dacromet Anti-Corrosion Coated Finish/Nylon Strap – 50mm \*7m

1. Set the ratchet switch to the neutral/middle position.
2. Pull the webbing out until the mounting holes in the base are visible.
3. Secure the winch using at least three (3) × 3/8" bolts with locking nuts, mounted in a triangular pattern.
4. Mount only to steel, reinforced timber, or a rigid structural surface.
5. Use a metal backing plate or hardwood spacer if required.

## Component Identification

- Ratchet switch
- Gear housing
- Crank handle
- Webbing drum
- Mounting base

## Operating Instructions

### Pulling / Tensioning

1. Set the ratchet switch to the high position.
2. Rotate the crank handle clockwise to pull or tension the load.
3. Select the appropriate gear ratio based on load resistance.

### Releasing Load

1. Set the ratchet switch to the low position.
2. Rotate the crank handle counter-clockwise to release tension gradually.
3. Maintain control of the handle at all times.

 Never allow the handle to spin freely under load.

## Maintenance & Service

### Lubrication & Rust Prevention

**Model: GWINCH503**

# **MAC AFRIC 2200lbs/1000kg HAND WINCH**

**With Dacromet Anti-Corrosion Coated Finish/Nylon Strap – 50mm \*7m**

- **Apply light lubricating oil to gears and axle points periodically**
- **Do not oil the nylon webbing**
- **Protect from corrosion during storage**

## **Inspection**

**Before each use, check:**

- **Webbing for fraying, cuts, or deformation**
- **Ratchet operation**
- **Gear engagement**
- **Mounting bolts for tightness**

**Replace damaged components immediately.**

## **Cleaning & Storage**

- **Remove dust, sand, and oil residue after use**
- **Store in a dry, ventilated area**
- **Avoid prolonged direct sunlight exposure**
- **Do not store under tension**

## **Storage Instructions**

- **Release all load before storage**
- **Lightly grease gears and axle for long-term storage**
- **Store flat and secured to prevent movement**



**Adendorff**  
**machinery mart**

# WARRANTY

Welcome to the Adendorff family! We're delighted to have you with us and thank you for choosing our product. Your trust and support are greatly appreciated, and we are confident that this device will serve you well.

**Please read this manual carefully before installation and use. It contains important safety information and operating instructions that must be followed to ensure proper and safe operation. Keep this manual for future reference.**

Taking the time to familiarise yourself with the product will help you maximise its performance and ensure a smooth, trouble-free experience.

If you have any questions or require assistance, please don't hesitate to contact our support team.

## WARRANTY TERMS AND CONDITIONS

### Warranty Period

- 12 months from purchase date (first user only).

### Coverage

- Manufacturing and material defects.
- Excludes: batteries, chargers, wear parts (bearings, brushes, cables, plugs), accessories (drills, drill bits, saw blades).

### Exclusions

- Misuse, maltreatment, accidents, or modifications.
- Overloading, fluid ingress, excessive dust, or intentional damage.
- Failure to follow instructions or use correct voltage.

### Liability

Adendorff Machinery Mart accepts no liability for injuries caused by improper use.

### Repairs

- Warranty repairs must be carried out at authorised Adendorff repair centres.
- A 3-month warranty applies to all repairs.

### Transport Costs

- Transport is the customer's responsibility unless agreed in writing.

### Claims

- Warranty claims require proof of purchase.
- Claims do not extend or reset the warranty period.

### Returns

- Return product intact, clean, and in original case (if applicable).
- Include proof of purchase.

For full warranty details, visit [www.adendorff.co.za](http://www.adendorff.co.za) or call 011 434 7000.

**⚠ Danger! Read all safety regulations and instructions. Keep this manual for future use.**

Supplied by:

Adendorff Machinery Mart

98 Sailor Malan Avenue, Aeroton, Johannesburg, 2190

[www.adendorff.co.za](http://www.adendorff.co.za)

Made in P.R.C.